

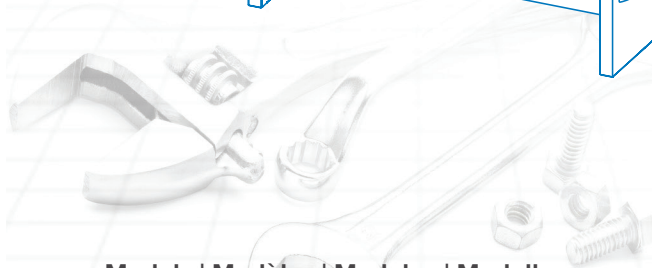

ROGUE® PRO-S

Assembly Guide
Guide d'assemblage
Guía de ensamblaje
Montageanleitung

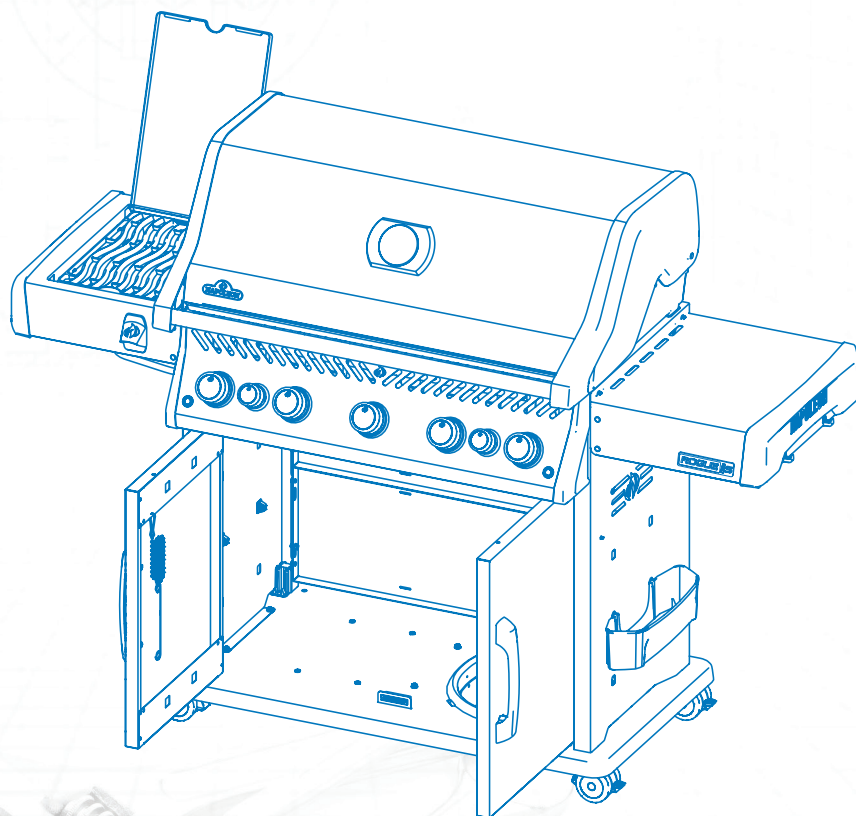

Models | Modèles | Modelos | Modelle

RPS425RSIB-2 | RPS525RSIB-2 | RPS625RSIB-2



(EN) Assembly Guidelines | (FR) Guide de montage | (ES) Guía de instalación |
 (DK) Retningslinjer for montering | (DE) Leitlinien für die Montage |
 (FI) Kokoonpano-ohjeet | (CZ) Pokyny pro montáž | (SK) Pokyny pre montáž |
 (SI) Smernice za montažo | (SE) Monteringsanvisningar | (UA) Посібник
 з монтажу | (PL) Wytyczne dotyczące montażu | (NO) Retningslinjer for
 montering | (NL) Richtlijnen voor montage | (IT) Linee guida per l'assemblaggio
 (HR) Smjernice za sastavljanje | (GR) Οδηγίες συναρμολόγησης

- | | |
|----------------------------------|-----------------------------|
| (EN) Safety requirements | (SE) Säkerhetskrav |
| (FR) Exigences de sécurité | (UA) Вимоги безпеки |
| (ES) Requerimientos de seguridad | (PL) Wymogi bezpieczeństwa |
| (DK) Krav til sikkerhed | (NO) Sikkerhetskrav |
| (DE) Sicherheitsanforderungen | (NL) Veiligheidseisen |
| (FI) Turvallisuusvaatimukset | (IT) Requisiti di sicurezza |
| (CZ) Bezpečnostní požadavky | (HR) Sigurnosni zahtjevi |
| (SK) Bezpečnostné požiadavky | (GR) Απαιτήσεις ασφαλείας |
| (SI) Varnostne zahteve | |



- | | |
|--|--|
| (EN) Installation tools (not included) | (SE) Installationsverktyg (ingår ej) |
| (FR) Outils d'installation (non inclus) | (UA) Інструменти для встановлення
(не входять до комплекту) |
| (ES) Herramientas de instalación
(no incluidas) | (PL) Narzędzia montażowe
(brak w zestawie) |
| (DK) Installationsværktøj (medfølger ikke) | (NO) Installasjonsverktøy (ikke inkludert) |
| (DE) Montagewerkzeug (nicht enthalten) | (NL) Installatiegereedschap
(niet meegeleverd) |
| (FI) Asennustyökalut (eivät sisälly) | (IT) Strumenti di installazione (non inclusi) |
| (CZ) Instalační nářadí (není součástí
balení) | (HR) Alati za instalaciju (nisu uključeni) |
| (SK) Inštaláčne náradie
(nie je súčasťou dodávky) | (GR) Εργαλεία εγκατάστασης
(δεν περιλαμβάνονται) |
| (SI) Orodja za namestitvev (niso vključena) | |



3/8
(10 mm)

3/8
(10 mm)

T30
TORX

Legend | Légende | Leyenda | Legende | Legende | Selite | Legenda
 Legenda | Legenda | Legend | Легенда | Legenda | Legende | Legende
 Legenda | Legenda | Υπόμνημα

	Warning! Avertissement ! ¡Advertencia! Advarsel! Warnung!	Varoitus! Varován! Varovanie! Opozorilo! Varning!	Обережно! Ostrzeżenie! Advarsel! Waarschuwing! Attenzione!	Upozorenje! Προειδοποίηση!
	Caution! Attention ! ¡Precaución! Forsigtig! Vorsicht!	Varoitus! Pozor! Pozor! Varning! Обережно!	Uwaga! Forsiktig! Let op! Attenzione! Oprez!	Προσοχή!
	Lock Bloc Bloquear Låse	Sperren Lukko Zámek Zámok	Zaklepanje Låsa Замок Zamek	Slot Serratura Brava Κλειδαριά
	Positioning Positionnement Posicionamiento Positionering Positionierung Paikannus	Polohování Polohovanie Pozicioniranje Positionering Позиціонування Pozycjonowanie	Positionering Posizionamento Pozicioniranje Τοποθέτηση	
	Use rubber mallet Utiliser un maillet en caoutchouc Use un mazo de goma Slå med gummihammer Mit Gummihammer schlagen Käytä kumivasaraa Použijte gumovou paličku Použite gumenú paličku Uporabite gumijasto kladivo		Använd gummiklubba Використовуйте гумовий молоток Użyj gumowego młotka Bruk gummihammer Gebruik een rubberen hamer Usa un martello di gomma Koristite gumeni čekić Χρησιμοποιήστε λαστιχένια σφύρα	
	Rotate the Unit Rotation de l'appareil Rotar la unidad Drej enheden Drehen Sie das Gerät Kierrä yksikköä	Otočte jednotku Otočte jednotku Zavrtite enoto Vrid enheten Обертайте пристрій Obróć urządzenie	Roter enheten Draai de eenheid Ruotare l'unità Okrenite jedinicu Περιστρέψτε τη μονάδα	

Legend | Légende | Leyenda | Legende | Legende | Selite | Legenda |
 Legenda | Легенда | Legende | Legende | Leggenda | Legenda | Υπόμνημα



Propane Only
 Propane uniquement
 Sólo propano
 Kun propan
 Nur Propan
 Vain propaani

Pouze propan
 Iba propán
 Samo propan
 Endast propan
 Тільки пропан
 Tylko propan

Kun propan
 Alleen propaan
 Solo propano
 Samo propan
 Μόνο προπάνιο



Natural Gas
 Gaz naturel
 Gas natural
 Naturgas
 Erdgas
 Maakaasu

Zemní plyn
 Zemný plyn
 Zemeljski plin
 Naturgas
 Природний газ
 Gazu ziemnego

Naturgass
 Natuurlijk gas
 Gas naturale
 Přírodní gas
 Φυσικό αέριο



Side Burner
 Brûleur latéral
 Quemador lateral
 Sidebrænder
 Seitenbrenner
 Sivupoltin

Boční hořák
 Bočný horák
 Stranski gorilnik
 Sidobrännare
 Бічний пальник
 Palnik boczny

Sidebrenner
 Zijbrander
 Fornello laterale
 Bočni plamenik
 Πλαϊνός καυστήρας



Non - Side Burner
 Sans brûleur latéral.
 Sin quemador lateral.
 Uden - Sidebrænder
 Ohne - Seitenbrenner
 Ilman sivupoltinta

Bez bočního hořáku
 Bez bočného horáka
 Brez stranskega
 gorilnika
 Utan sidobrännare
 Без бічної конфорки

Bez palnika bocznego
 Uten sidebrenner
 Zonder zijbrander
 Senza fornello laterale
 Bez bočnog plamenika
 Χωρίς Πλαϊνό Καυστήρα



Remove film.
 Retirer le film.
 Retire la película
 Fjern film
 Folie entfernen
 Poista kalvo

Odstraňte fólii
 Odstráňte film
 Odstranite film
 Ta bort filmen
 Зняти плівку
 Usuń folię

Fjern filmen
 Verwijder folie
 Rimuovere la
 pellicola
 Uklonite film
 Αφαιρέστε το φιλμ



Caution Head Injury
 Attention blessure à la tête
 Atención lesión craneal
 Forsigtig Hovedskade
 Vorsicht Kopfverletzung
 Varoitus Pään vamma

Pozor Poranění hlavy
 Pozor Poranenie hlavy
 Pozor Poškodba glave
 Varning Huvudskada
 Bez bichnoyi konforky
 Uwaga, uraz głowy

Forsiktig Hodeskade
 Let op hoofdletsel
 Attenzione ferita alla testa
 Oprez Ozljeda glave
 Προσοχή Τραυματισμός
 στο κεφάλι

WELCOME TO NAPOLEON!

Congratulations on upgrading your grilling game and welcome to the **NAPOLEON** family!



Ready to assemble your new grill?



There may be visual differences between illustrations and model purchased. Remove all parts from packaging before assembling the barbecue. Set up this assembly on a solid, level and horizontal surface.

BIENVENUE À NAPOLEON!

Félicitations pour votre achat et bienvenue dans la famille **NAPOLEON**!



Prêt à assembler votre nouveau grill?



Veuillez noter qu'il peut y avoir des différences entre les illustrations de ce guide et le modèle acheté. Retirez toutes les pièces de leur emballage avant de commencer. Veillez à assembler votre grill sur une surface plane et solide.

¡BIENVENIDO A NAPOLEON!

¡Felicidades por mejorar tu juego de parrilla y bienvenido a la familia **NAPOLEON**!



¿Listo para ensamblar tu nueva parrilla?



Tenga en consideración que puede haber diferencias entre las ilustraciones en esta guía y el modelo adquirido. Remueva todas las piezas de sus empaques antes de comenzar. Asegúrese de ensamblar la parrilla en una superficie plana y sólida.

VELKOMMEN TIL NAPOLEON!

Tillykke med, at du har opgraderet dit grillspil, og velkommen til **NAPOLEON**-familien!



Er du klar til at samle din nye grill?



Der kan være visuelle forskelle mellem illustrationer og den købte model. Tag alle dele ud af emballagen, før du samler grillen. Stil grillen op på en solid, plan og vandret overflade.

WILLKOMMEN BEI NAPOLEON!

Herzlichen Glückwunsch zur Aufrüstung Ihres Grills und willkommen in der **NAPOLEON**-Familie!



Sind Sie bereit, Ihren neuen Grill zusammenzubauen?



Es kann optische Unterschiede zwischen den Abbildungen und dem gekauften Modell geben. Nehmen Sie vor dem Zusammenbau des Grills alle Teile aus der Verpackung. Stellen Sie die Baugruppe auf einer festen, ebenen und horizontalen Fläche auf.

TERVETULOA NAPOLEONIIN!

Onnittelut grillauspelisi päivittämisestä ja tervetuloa **NAPOLEON**-perheeseen!



Oletko valmis kokoamaan uuden grillisi?



Kuvissa ja ostetussa mallissa voi olla visuaalisia eroja. Poista kaikki osat pakkauksesta ennen grillin kokoamista. Aseta tämä kokoonpano kiinteälle, tasaiselle ja vaakasuoralle alustalle.

VÍTEJTE V NAPOLEONU!

Blahopřejeme vám k vylepšení vaší grilovací hry a vítáme vás v rodině **NAPOLEON!**



Jste připraveni sestavit svůj nový gril?



Mezi ilustracemi a zakoupeným modelem mohou být vizuální rozdíly. Před sestavením grilu vyjměte všechny díly z obalu. Tuto sestavu postavte na pevný, rovný a vodorovný povrch.

VITAJTE V NAPOLEONE!

Blahoželáme vám k vylepšeniu vašej grilovacej hry a vítame vás v rodine **NAPOLEON!**



Ste pripravení zostaviť svoj nový gril?



Medzi ilustráciami a zakúpeným modelom môžu byť vizuálne rozdiely. Pred zostavením grilu vyberte všetky diely z obalu. Túto zostavu postavte na pevný, rovný a vodorovný povrch.

DOBRODOŠLI V NAPOLEONU!

Čestitamo vam, da ste izboljšali svojo igro na žaru, in vas pozdravljamo v družini **NAPOLEON!**



Ste pripravljani na montažo svojega novega žara?



Med ilustracijami in kupljenim modelom so lahko vizualne razlike. Pred sestavljanjem žara odstranite vse dele iz embalaže. Ta sklop postavite na trdno, ravno in vodoravno površino.

VÄLKOMMEN TILL NAPOLEON!

Grattis till att du har uppgraderat din grillning och välkommen till **NAPOLEON**-familjen!



Är du redo att montera din nya grill?



Det kan förekomma visuella skillnader mellan illustrationer och den modell som köpts. Ta bort alla delar från förpackningen innan du monterar grillen. Ställ upp enheten på ett stabilt, plant och horisontellt underlag.

ЛАСКАВО ПРОСИМО НА НАПОЛЕОН!

Вітаємо з оновленням вашого гриля та ласкаво просимо до сім'ї **NAPOLEON!**



Готові зібрати свій новий гриль?



Можливі візуальні відмінності між ілюстраціями та придбаною моделлю. Вийміть всі деталі з упаковки, перш ніж збирати гриль. Встановіть цю збірку на тверду, рівну і горизонтальну поверхню.

WITAMY W NAPOLEON!

Gratulujemy ulepszenia swojego grilla i witamy w rodzinie **NAPOLEON!**



Gotowy do montażu nowego grilla?



Mogą występować różnice wizualne między ilustracjami a zakupionym modelem. Przed złożeniem grilla należy wyjąć wszystkie części z opakowania. Ustaw urządzenie na solidnej, równej i poziomej powierzchni.

VELKOMMEN TIL NAPOLEON!

Gratulerer med oppgraderingen av grillspillet ditt, og velkommen til **NAPOLEON**-familien!



Er du klar til å montere din nye grill?



Det kan være visuelle forskjeller mellom illustrasjonene og modellen du har kjøpt. Ta alle delene ut av emballasjen før du monterer grillen. Sett opp denne enheten på en solid, jevn og vannrett overflate.

WELKOM BIJ NAPOLEON!

Gefeliciteerd met het upgraden van uw grill spel en welkom bij de **NAPOLEON** familie!



Klaar om uw nieuwe grill te monteren?



Er kunnen visuele verschillen zijn tussen de illustraties en het gekochte model. Haal alle onderdelen uit de verpakking voordat u de barbecue in elkaar zet. Zet dit geheel op een stevige, vlakke en horizontale ondergrond.

BENVENUTO A NAPOLEON!

Congratulazioni per aver migliorato il vostro gioco di grigliate e benvenuti nella famiglia **NAPOLEON**!



Siete pronti ad assemblare il vostro nuovo grill?



Potrebbero esserci differenze visive tra le illustrazioni e il modello acquistato. Rimuovere tutte le parti dall'imballaggio prima di assemblare il barbecue. Posizionare il gruppo su una superficie solida, piana e orizzontale.

DOBRODOŠLI U NAPOLEON!

Čestitamo na unapređenju vaše igre roštiljanja i dobrodošli u **NAPOLEON** obitelji!



Spremni za sastavljanje vašeg novog roštilja?



Može biti vizualnih razlika između ilustracija i kupljenog modela. Uklonite sve dijelove iz pakiranja prije sastavljanja roštilja. Postavite ovu montažu na čvrstu, ravnu i vodoravnu površinu.

ΚΑΛΩΣ ΗΛΘΑΤΕ ΣΤΟ NAPOLEON!

Συγχαρητήρια για την αναβάθμιση του παιχνιδιού ψησίματος και καλωσορίσατε στην οικογένεια **NAPOLEON**!



Είστε έτοιμοι να συναρμολογήσετε τη νέα σας ψησταριά;



Ενδέχεται να υπάρχουν οπτικές διαφορές μεταξύ των απεικονίσεων και του μοντέλου που αγοράσατε. Αφαιρέστε όλα τα εξαρτήματα από τη συσκευασία πριν συναρμολογήσετε το μπάρμπεκιου. Τοποθετήστε αυτό το συγκρότημα σε μια σταθερή, επίπεδη και οριζόντια επιφάνεια.

Models | Modèles | Modelos | Modelle

RPS425

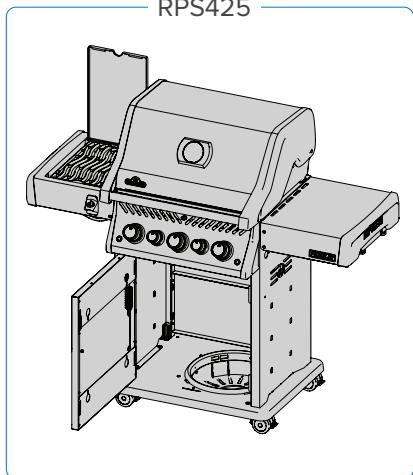

RPS525

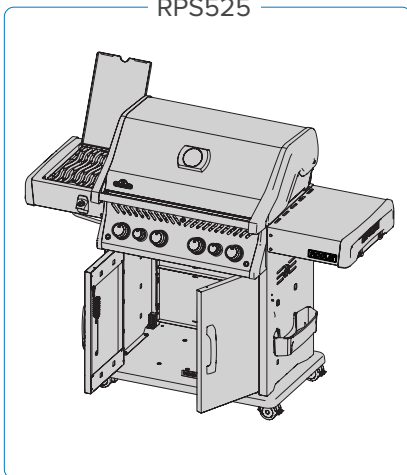

RPS625

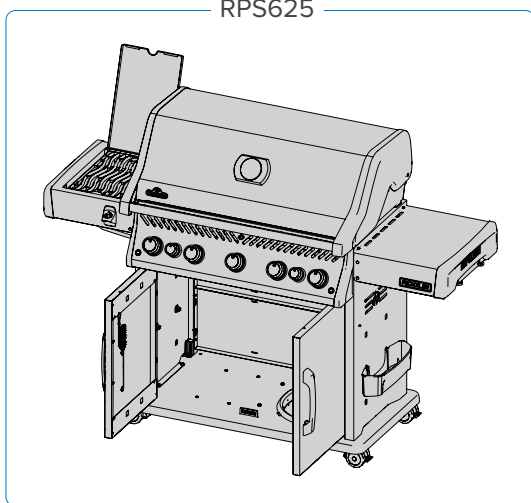





Assembly Steps

Étapes d'assemblage

Pasos para la instalación

Montageschritte

1

 x4

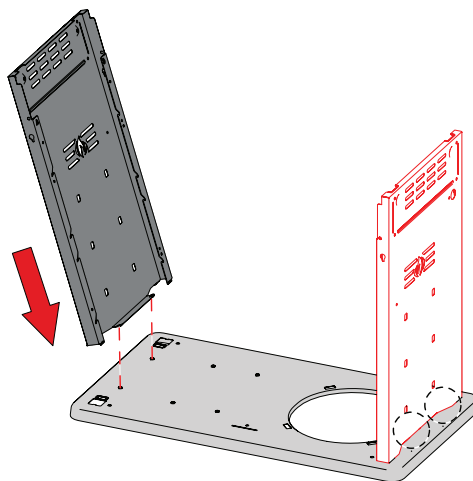
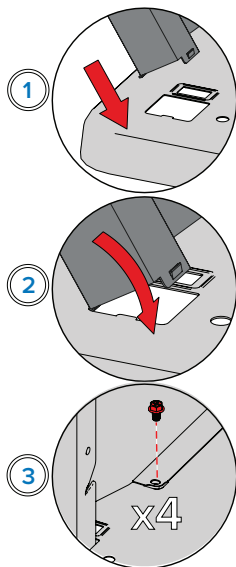

2

 x8  x2

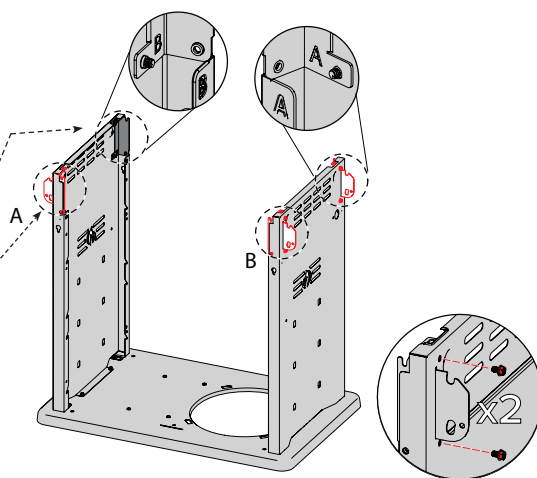
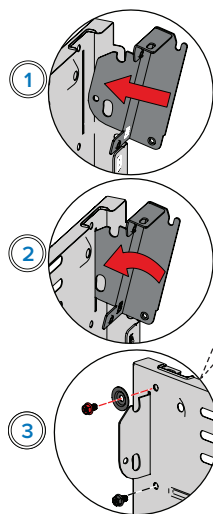

3

 x4

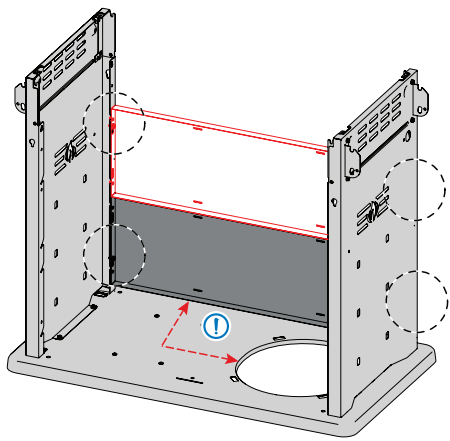
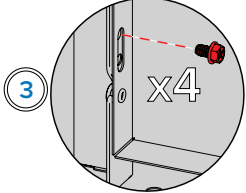
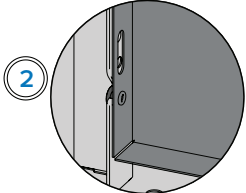
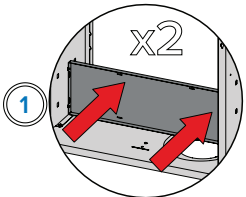

4

 x2

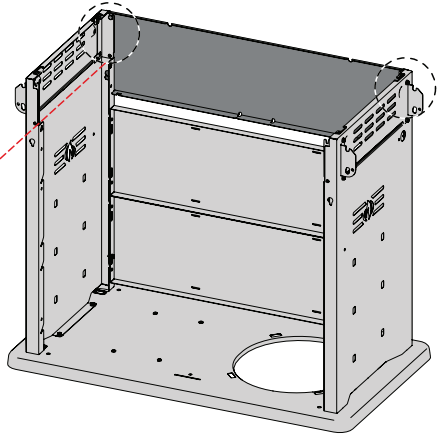
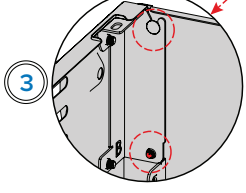
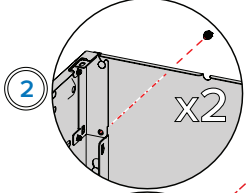
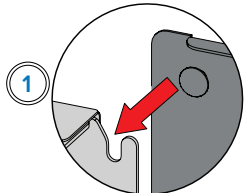

5

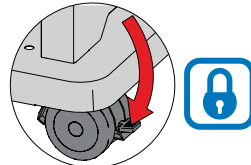
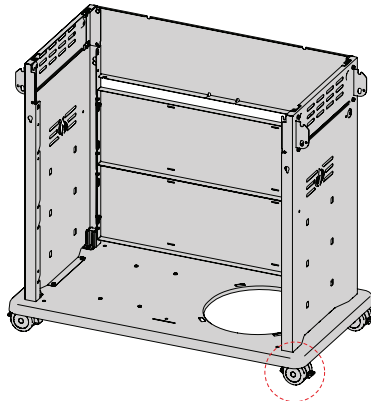
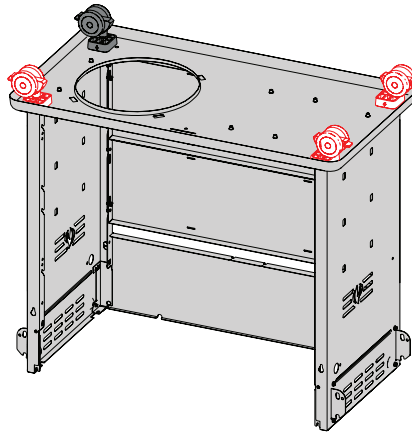
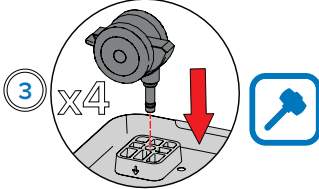
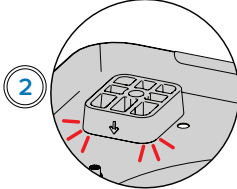
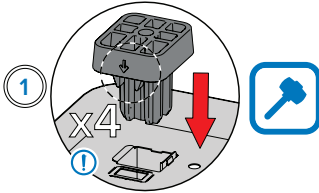
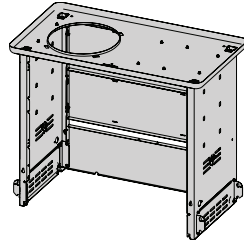

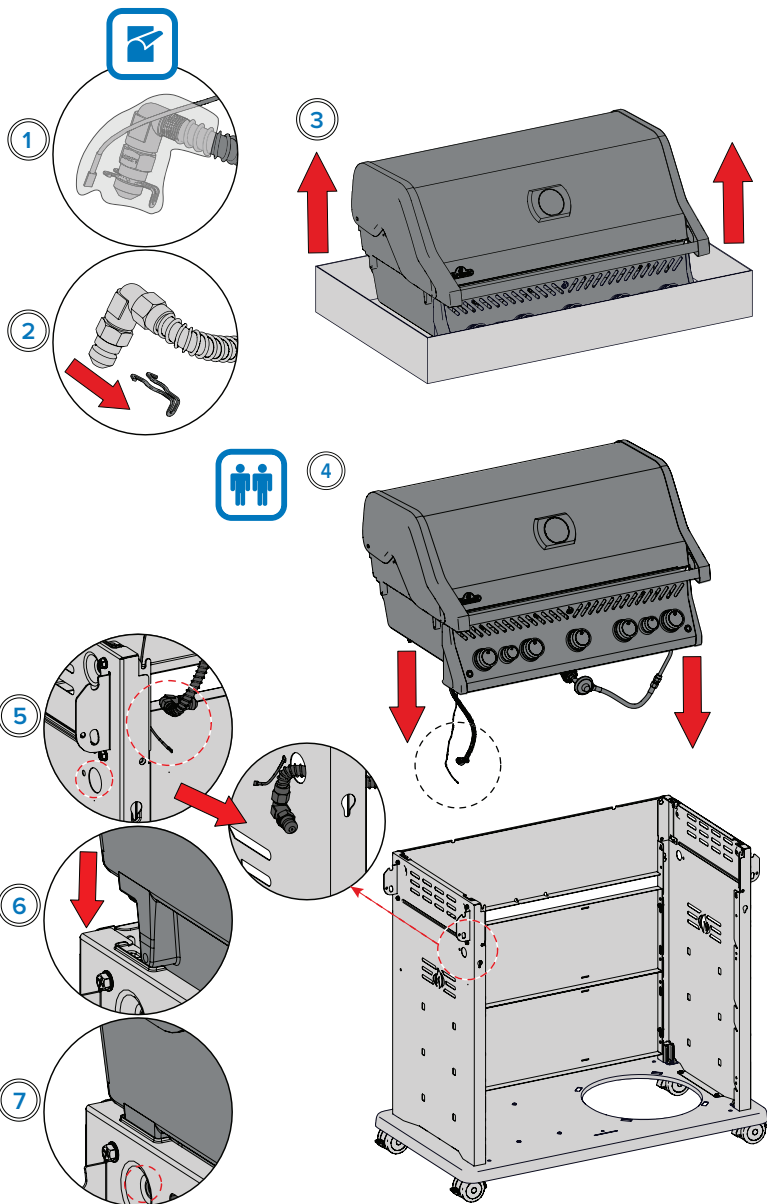



7

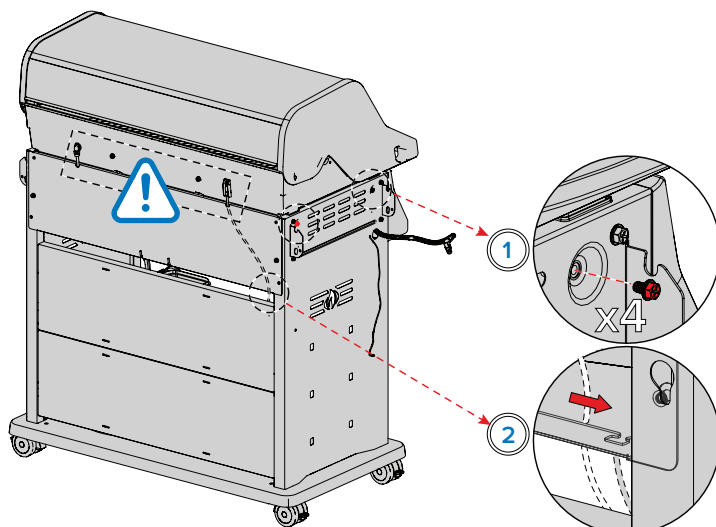

8

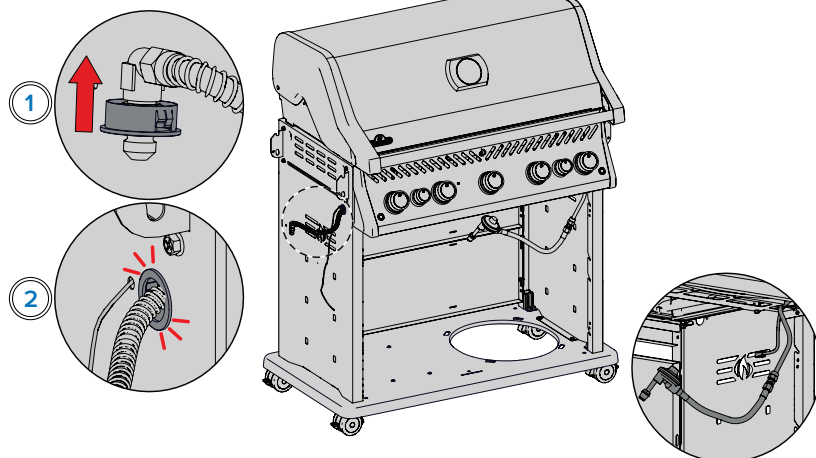

9

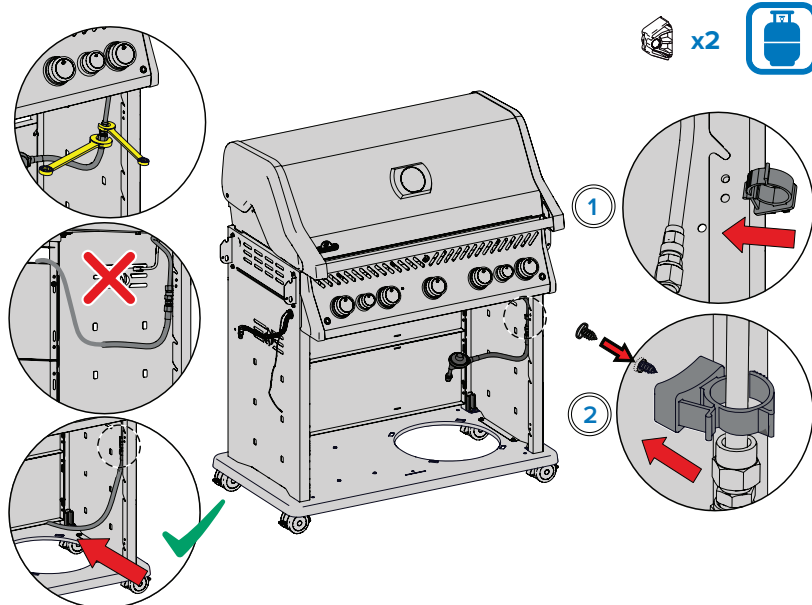

10

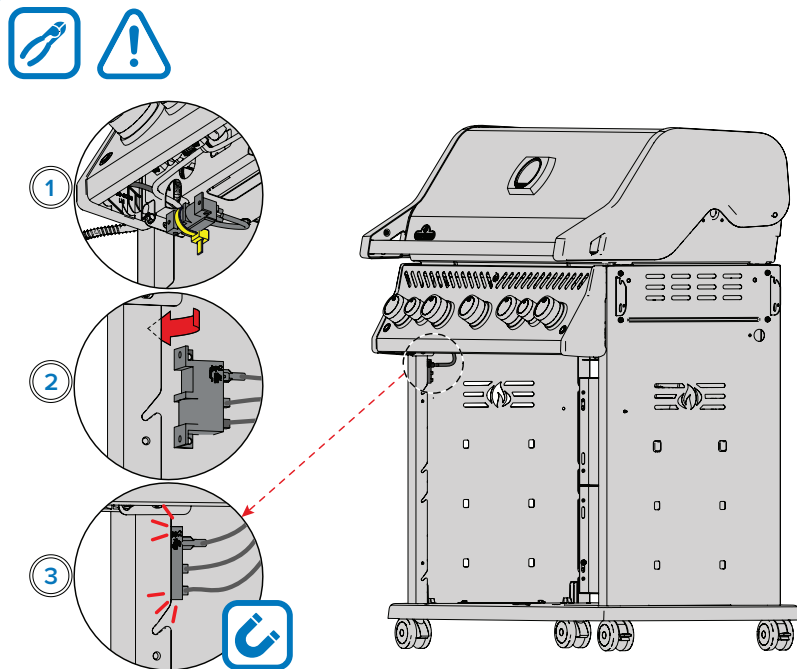

11

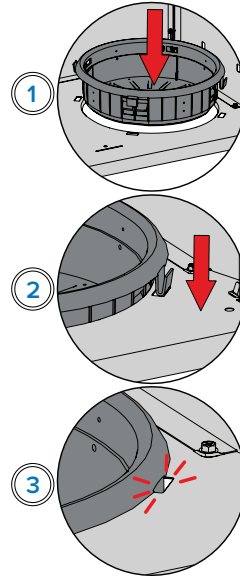
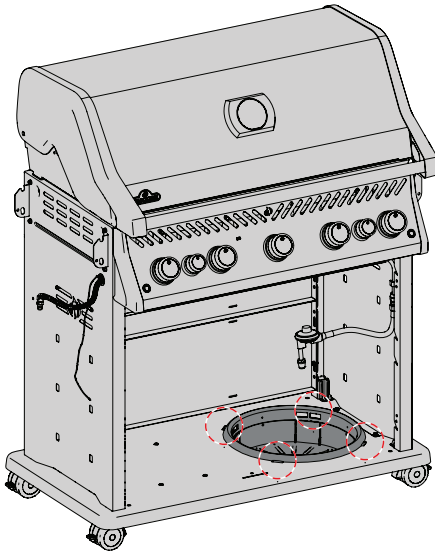

12



x1 (625 / 525)

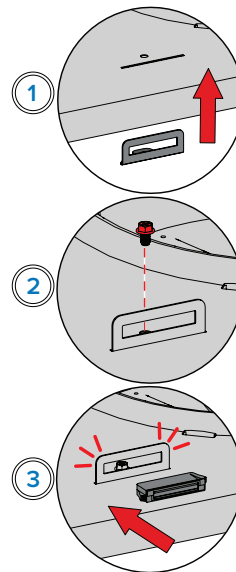
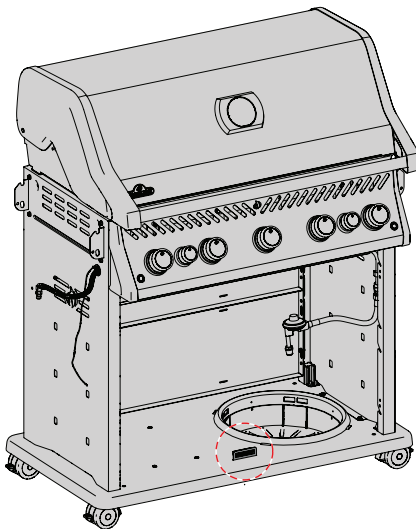

13



x2 (425)

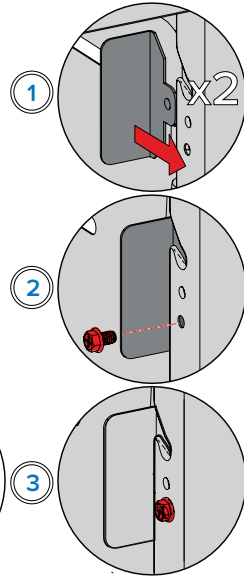
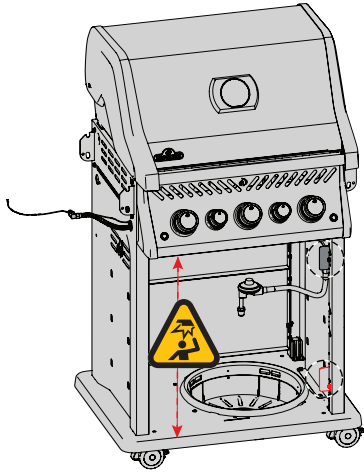

14

x2

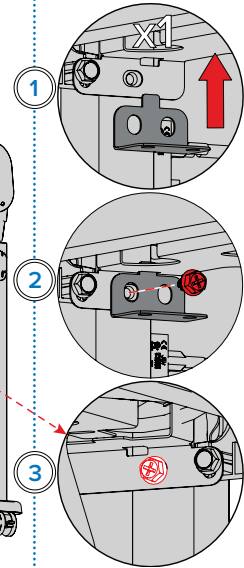
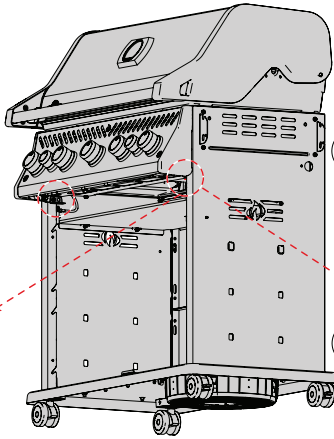
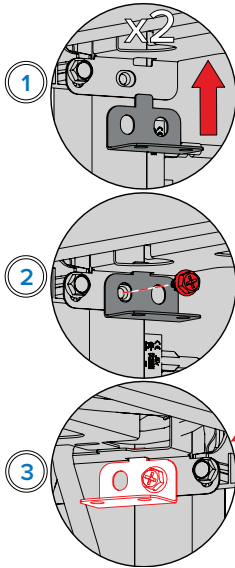

15

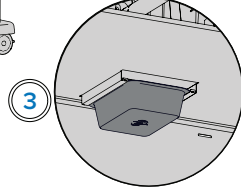
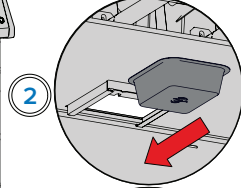
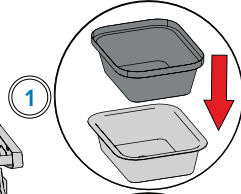
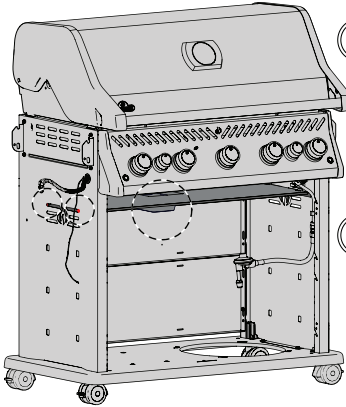
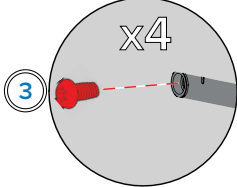
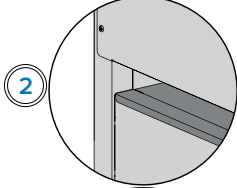
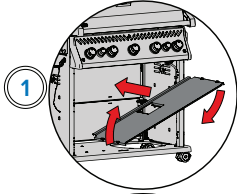

16

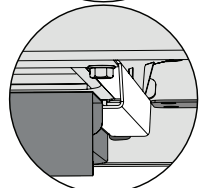
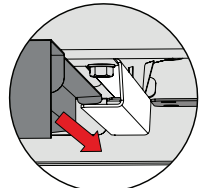
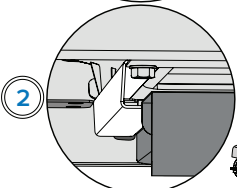
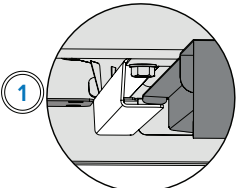
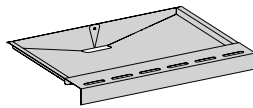
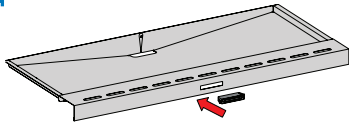

17

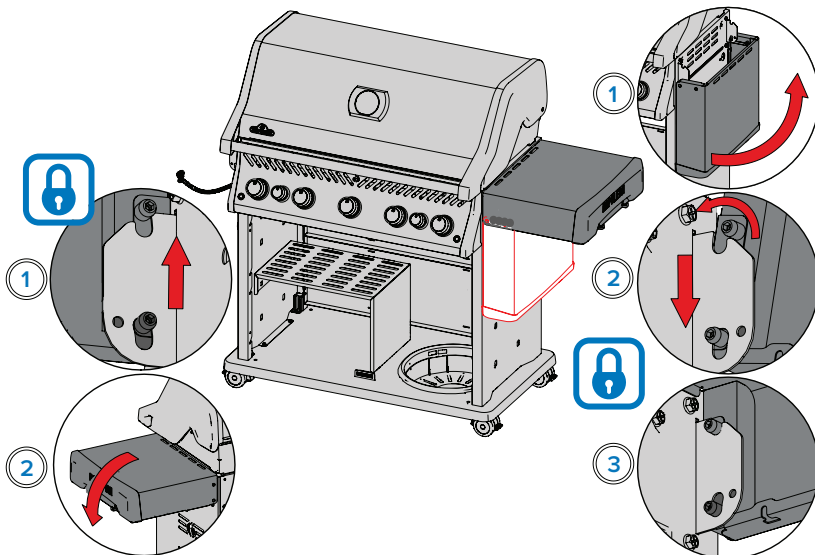

18

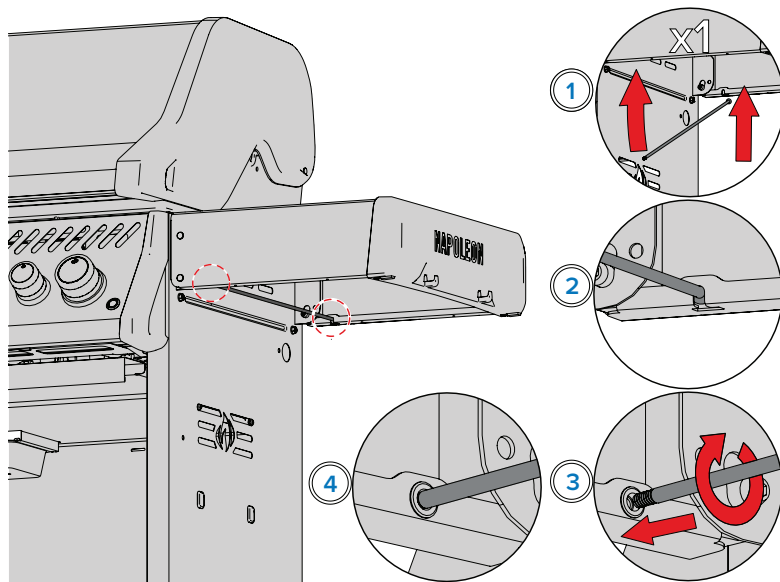

19

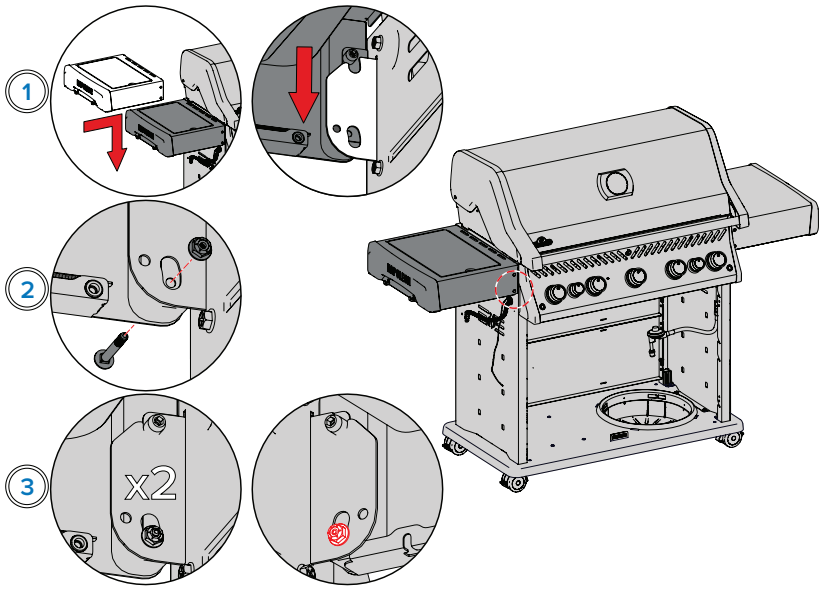

20

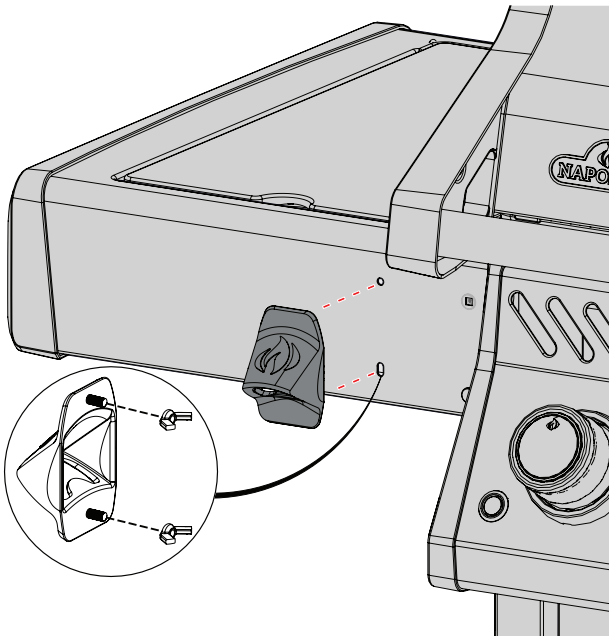

21

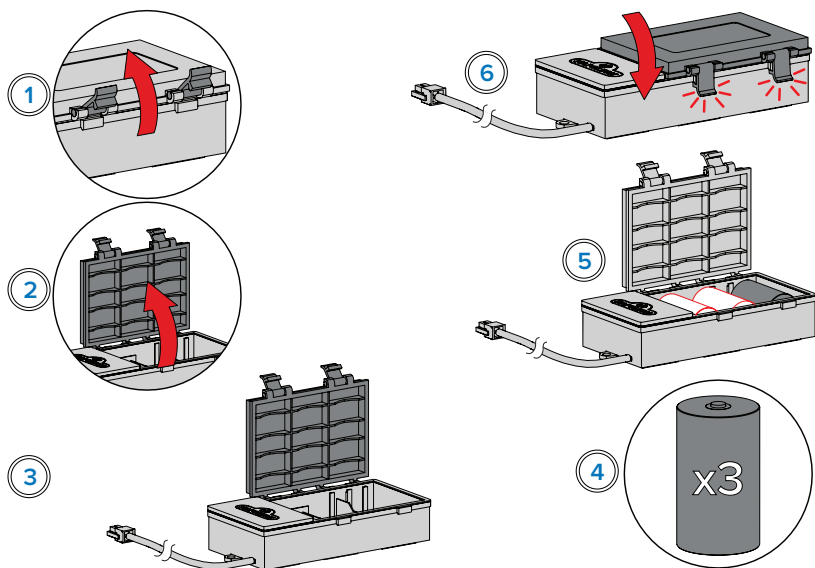

22

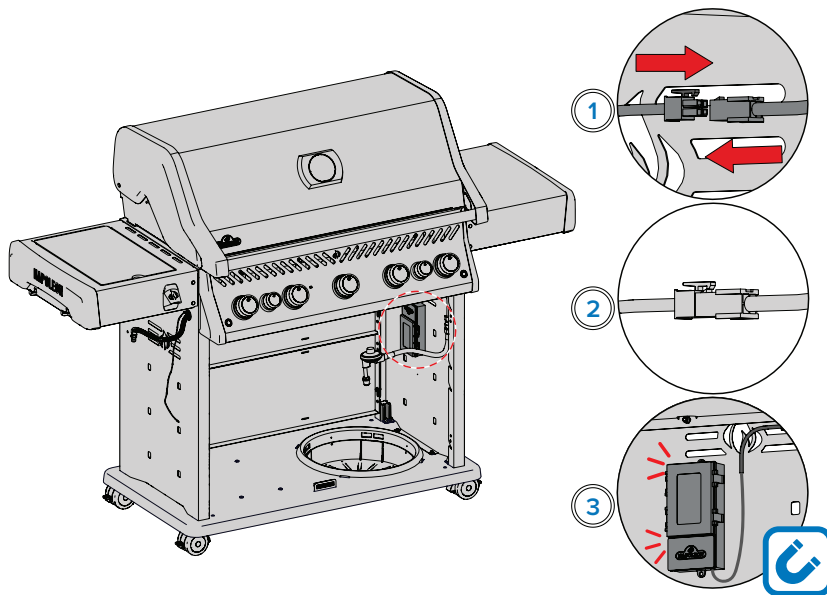

23

 x4 (625 / 525)  x2 (425)

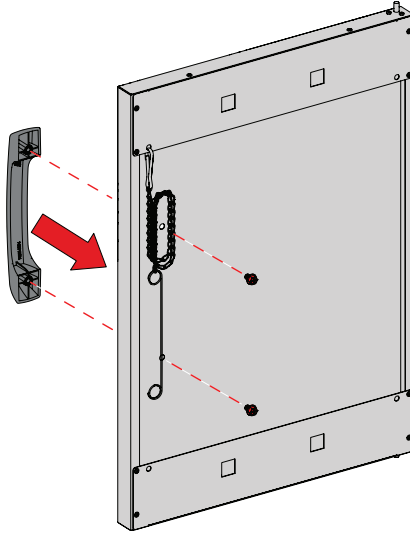

24

 x2 (625 / 525)  x1 (425)

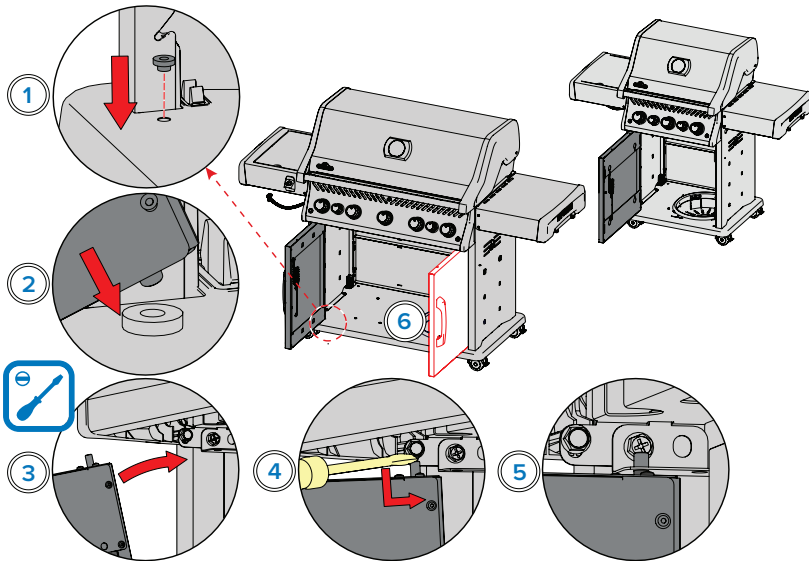

25

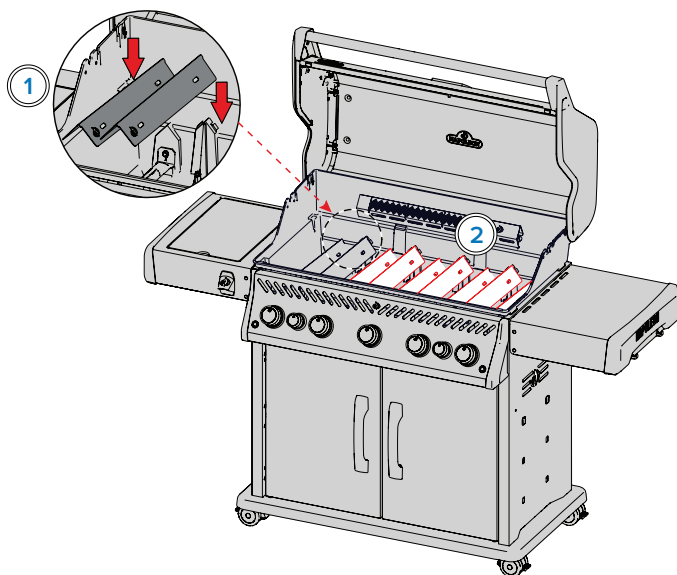

26

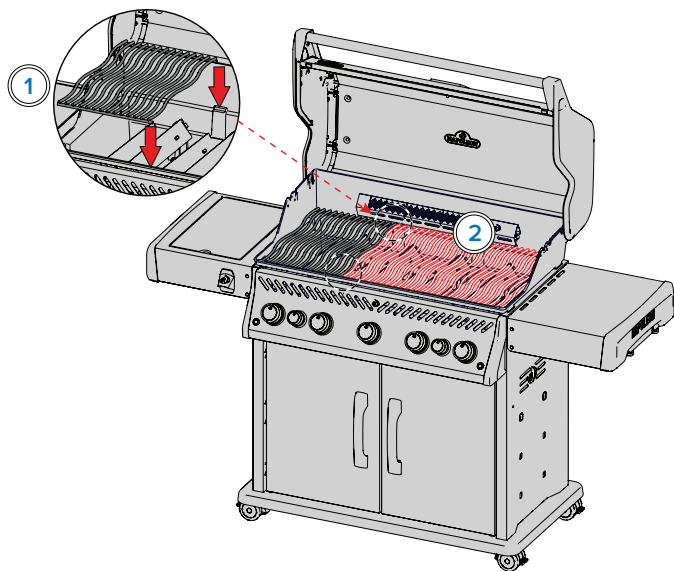

27

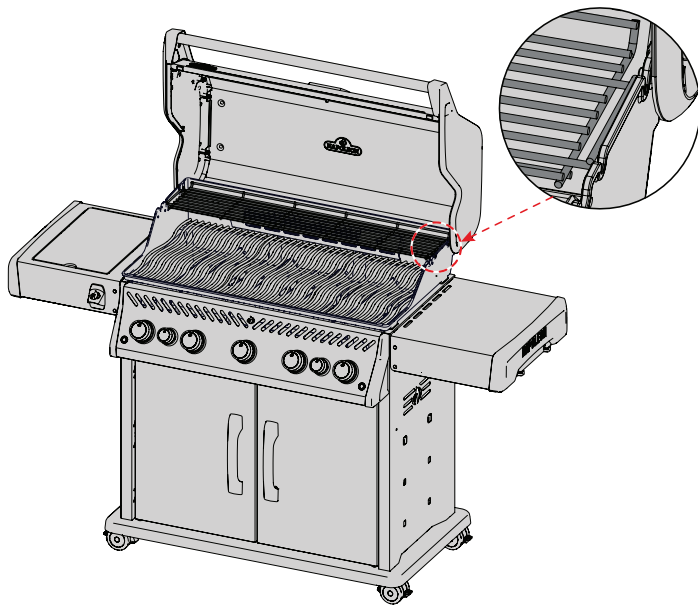

28

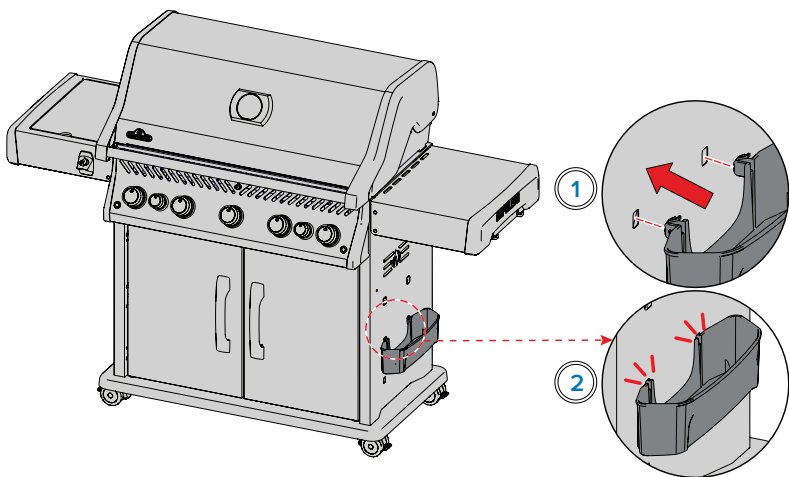

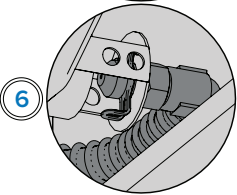
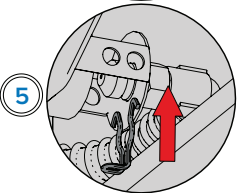
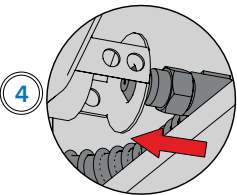
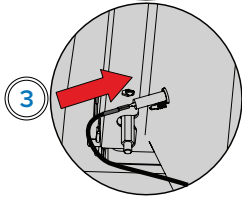
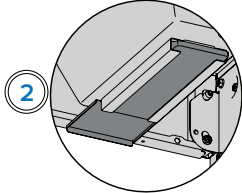
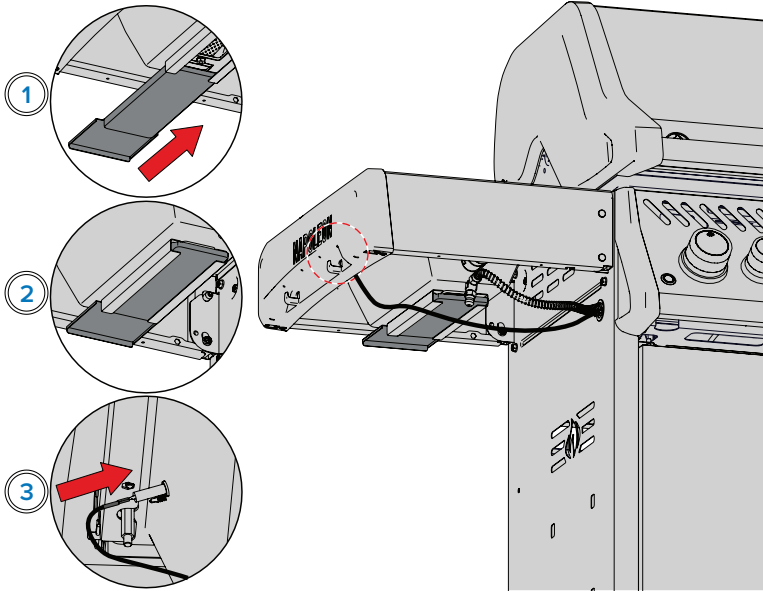

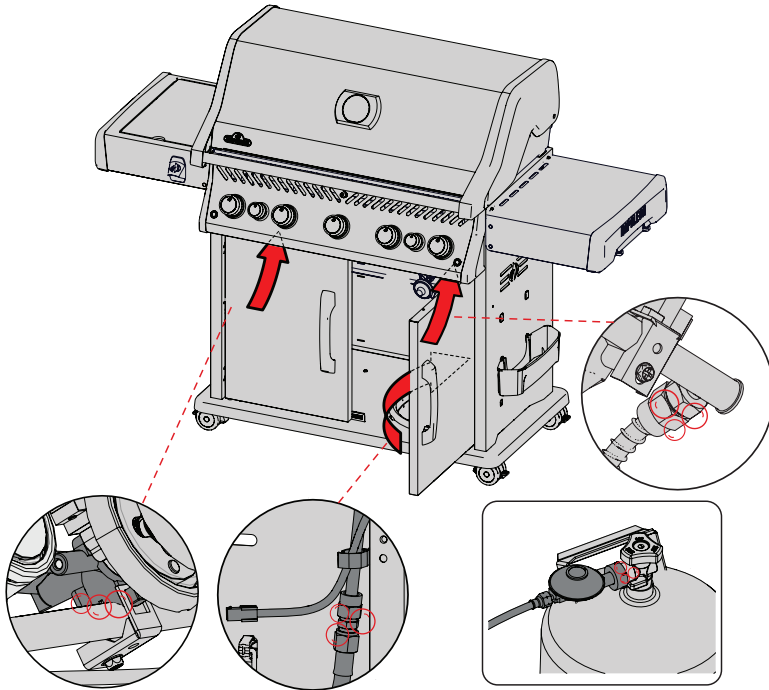
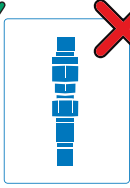
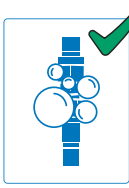





Parts List

Liste des pieces

Lista de piezas

Liste der Einzelteile



Legend | Légende | Leyenda | Legende

Legend	Légende	Leyenda	Legende
x - standard part	x - standard	x - estándar	x - standardteil
p - propane	p - propane	p - propano	p - propan
n - natural gas	n - gas naturel	n - gas natural	n - erdgas
ac - accessory	ac - accessoire	ac - accesorio	ac - zubehörteil
alt - alternate	alt - alternatif	alt - alternativa	alt - alternativ

	Part # Partie # Parte # Teil #	RPS425	425-PHM	RPS525	525-MK	RPS625	Description Description Descripción Beschreibung
1	N010-1754-SS	x					Lid Assembly Assemblage du couvercle Set de ensamblado de la tapa Deckelmontage
	N010-1754-BK	x					
	N010-1754-MK		x				
	N010-1754-SS			x			
	N010-1755-BK			x			
	N010-1755-MK				x		
	N010-1756-SS					x	
	N010-1756-BK					x	
2	S91015	x		x		x	Temperature Gauge Jauge de température Indicador de temperatura Temperaturanzeige
	S91010		x		x		
3	N385-0513-SER	x		x	x	x	Napoleon Logo Logo Napoléon Logo Napoleón Napoleon-Logo
	N385-0513-BK-SER		x				
4	N510-0013	x	x	x	x	x	Rectangular Bumper Pare-chocs rectangulaire Parachoques rectangular Rechteckiger Stoßfänger
5	S87014	x	x	x	x	x	Pivot Lid Pin Goupille de couvercle pivotant Pasador de tapa pivotante Deckelschwenkstift
6	N010-1149-SER	x					Base Casting Assembly Assemblage de la base de coulée Conjunto de fundición base Socket Guss Montage
	N010-1466-SER		x				
	N010-1150-SER			x			
	N010-1150-MK-SER				x		
	N010-1235-SER					x	



	Part # Partie # Parte # Teil #	RPS425	425-PHM	RPS525	525-MK	RPS625	Description Description Descripción Beschreibung
7	N240-0040	x	x	x	x	x	Electrode Électrode Electrodo Elektrode
8	N570-0104	x	x	x	x	x	Screw Vis Tornillo Schraube
9	N350-0087	x	x	x	x	x	Rear Burner Housing Boîtier du brûleur arrière Carcasa del quemador trasero Hinteres Brennergehäuse
10	N100-0058	x	x	x	x	x	Rear Burner Brûleur arrière Quemador trasero Hinterer Brenner
11	N720-0082	x	x	x	x	x	Flex Connector Connecteur flexible Conector flexible Flex-Anschluss
12	N160-0043	x	x	x	x	x	Flex Line Clip Clip pour ligne flexible Clip de línea flexible Flex Line Clip
13	S87010	x	x				Cross Light Bracket Support d'éclairage transversal Soporte de luz transversal Kreuzlichthalterung
	S87013			x	x		
	S87017					x	
14	N080-0423	x	x				Cross Light Folding Bracket Support pliant pour feux de croisement Soporte plegable de luz transversal Kreuzlicht- Klappbügel
	N080-0418			x	x		
	N080-0443					x	
15	S87001	x	x	x	x	x	Sear Burner Kit Kit brûleur de cuisson Kit quemador para dorar Anbratbrenner-Kit
16	N305-0082	x	x	x	x	x	Sear Plate Plaque de séchage Placa Sear Anbratplatte
17	N100-0060	x	x	x	x	x	Main Burner Brûleur principal Quemador principal Hauptbrenner



	Part # Partie # Parte # Teil #	RPS425	425-PHM	RPS525	525-MK	RPS625	Description Description Descripción Beschreibung
17*	N100-0060-IL	alt	alt	alt	alt	alt	Main Burner Brûleur principal Quegador principal Hauptbrenner
18	N520-0055	x					Warming Rack Support de réchauffage Rejilla para calentar Warmhaltegestell
	71501	ac	x				
	N520-10001898			x	x		
	N520-10001899					x	
19	S83043	x	x				Stainless Steel Grids Grilles en acier inoxydable Rejillas de acero inoxidable Roste aus rostfreiem Stahl
	S83044			x	x		
	S83045					x	
	S83008	ac	ac				Cast Iron Grids Grilles en fonte Rejillas de hierro fundido Gusseisen- Gitterroste
	S83024			ac	ac		
	S83021					ac	
20	N455-0097	x	x	x	x	x	Rear Orifice Orifice arrière Orificio trasero Hintere Blende
21	N200-0118-GY1SG	x					Base Back Cover Couvercle arrière de la base Tapa trasera de la base Basis Rückwand
	N200-0118-BK1TX		x				
	N200-0127-GY1SG			x			
	N200-0127-BK1FL				x		
	N200-0135-GY1SG					x	
22	N570-0145-GY	x	x	x	x	x	T30 TORX Screw Vis T30 TORX Tornillo T30 TORX T30 TORX-Schraube
23	N585-0145-GY1SG	x					Cabinet Heat Shield Bouclier thermique de l'armoire Escudo térmico del armario Hitzeschild für das Gehäuse
	N585-0145-BK1TX		x				
	N585-0121-GY1SG			x			
	N585-0121-BK1FL				x		
	N585-0144-GY1SG					x	
24	N710-0062	x	x	x	x	x	Grease Tray Bac à graisse Bandeja de grasa Fettauffangwanne
	62007	ac	ac	ac	ac	ac	



	Part # Partie # Parte # Teil #	RPS425	425-PHM	RPS525	525-MK	RPS625	Description Description Descripción Beschreibung
25	N475-0363-GY1SG	x					Rear Cart Panel
	N475-0363-BK1TX		x				Panneau arrière du chariot
	N475-0449-GY1SG			x			Panel trasero del carro
	N475-0449-BK1FL				x		Hinteres Wagenpaneel
	N475-0499-GY1SG					x	
26	N080-0364	x	x	x	x	x	Shelf Bracket A
							Support d'étagère A
27	N350-0077LY	x	x	x	x	x	Soporte de estante A
							Regalhalterung A
							Battery Housing
28	N710-0094	x	x				Boîtier de batterie
	N710-0108			x	x		Alojamiento de la batería
	N710-0120					x	Batteriegehäuse
	N710-0120					x	
29	N080-0378-GY1SG	x		x		x	Pivot Door Bracket
	N080-0378-BK1SG		x		x		Support de porte pivotante
30	N430-0002			x	x	x	Soporte de puerta pivotante
							Halter für Drehtür
							Magnetic Catch
31	N080-0365	x	x	x	x	x	Loquet magnétique
							Cierre magnético
32	N750-0016	x	x	x	x	x	Magnetische Verriegelung
							Shelf Bracket B
							Support d'étagère B
33	N357-0021LY	x	x	x	x	x	Soporte de estante B
							Regalhalterung B
34	N455-0112	x	x	x	x	x	Side Burner
							Igniter Box
							Boîte d'allumage
							Caja de Ignición
							Anzünder-Box
							Orifice Orifice
							Orificio Blende







	Part # Partie # Parte # Teil #	RPS425	425-PHM	RPS525	525-MK	RPS625	Description Description Descripción Beschreibung
35	N160-0023	x	x	x	x	x	Orifice Retainer Clip Clip de retenue d'orifice Clip de retención del orificio Halteklammer für die Blende
36	N255-0064	x	x	x	x	x	Elbow Fitting Raccord coudé Codo Winkelverschraubung
37	N720-0055	x	x	x	x	x	Flex Hose Assembly Ensemble de tuyau flexible Conjunto de manguera flexible Flexschlauch- Baugruppe
38	W105-0010	x	x	x	x	x	Bushing Bague Amortiguador Buchse
39	N080-0380-GY1SG	x					
	N080-0380-BK1SG		x				Magnet Bracket Support magnétique
	N080-0387-GY1SG			x		x	Soporte Imán
	N080-0387-BK1SG				x		Magnet-Halterung
40	N570-0118	x	x	x	x	x	Screw Vis Tornillo Schraube
41	N130-0015	x	x	x	x	x	Caster Roue dentée Rueda Nachlauf
42	N510-0015	x	x	x	x	x	Caster Socket Socle de roulette Zócalo de ruedas Nachlaufsockel
43	N590-0292-GY1SG	x					
	N590-0292-BK1TX		x				Cart Bottom Shelf Tablette inférieure du chariot
	N590-0282-GY1SG			x			Estante inferior del carro
	N590-0282-BK1FL				x		Unteres Wagenregal
	N590-0326-GY1SG					x	
44	N475-0607-GY1SG	x		x		x	Cabinet Side Panel Panneau latéral de l'armoire
	N475-0607-BK1TX		x		x		Panel lateral del gabinete Seitenwand des Gehäuses





	Part # Partie # Parte # Teil #	RPS425	425-PHM	RPS525	525-MK	RPS625	Description Description Descripción Beschreibung
45	N530-0032	x	x	x	x	x	Propane Regulator Régulateur de propane Regulador de propano Propan-Regler
	N530-0033	x	x	x	x	x	
	N530-0034	x	x	x	x	x	
	N530-0035	x	x	x	x	x	
	N530-0036	x	x	x	x	x	
	N530-0037	x	x	x	x	x	
	N530-0038	x	x	x	x	x	
	N530-0039	x	x	x	x	x	
	N530-0042	x	x	x	x	x	
	N530-0043	x	x	x	x	x	
	N530-0046	x	x	x	x	x	
46	N255-0027	x	x	x	x	x	Union Fitting Raccord union Accesorio de unión Verschraubung
47	N590-0261	x		x		x	Condiment Tray Plateau à condiments Bandeja de condimentos
	N590-0261-BK0TX		x		x		
48	N370-0981CE	p	p	p	p	p	Propane Tank Tray Plateau pour réservoir de propane Bandeja del tanque de propano Propan-Tankwanne
49	N010-0869-SS-SER	x					Single Door Assembly Assemblage de porte simple Conjunto de puerta simple Einzelne Türmontage
	N010-0869-BK-SER	x					
	N010-0869-BX-SER		x				
	N010-0984-SS-SER			x			
	N010-0984-BK-SER			x			
	N010-0984-MK-SER				x		
	N010-1221-SS-SER					x	
	N010-1221-BK-SER					x	
50	N010-1782-SS	x		x		x	Right Side Shelf Tablette latérale droite Estante del lado derecho Rechte Seitenablage
	N010-1782-MK		x		x		
51	N370-0928-SER	x		x		x	Shelf Kit Kit d'étagères Kit de estantes Regal-Bausatz
	N370-0928-BK-SER		x		x		



	Part # Partie # Parte # Teil #	RPS425	425-PHM	RPS525	525-MK	RPS625	Description Description Descripción Beschreibung
52	N385-10001898-SER	x	x	x	x	x	Rogue PRO-S Logo
	N385-10001898-BK						Logo Rogue PRO-S Logo Rogue PRO-S Logo Rogue PRO-S Logo Rogue PRO-S
53	N080-0380-GYISG	x		x			Magnet Bracket Support magnétique Soporte Imán Magnet-Halterung
54	N555-0097	x	x	x	x	x	Lighting Match Rod Tige d'allumage Varilla de fósforo Beleuchtung Streichholzstab
55	N325-0094-SER	x		x		x	Door Handle Poignée de porte Manija de la puerta Türklinke
	N325-0094- BK0TX-SER		x		x		
56	N105-0011	x	x	x	x	x	Door Pivot Bushing Douille de pivot de porte Casquillo pivote de puerta Türzapfenbuchse
57	N370-0745	ac	ac	ac	ac	ac	Rotisserie Mount Kit Kit de montage pour rôtissoire Kit de montaje para asador Rotisserie- Montagesatz
58	N080-0422-SER	x		x	x	x	Bottle Opener Ouvre-bouteille Abrebotellas Flaschenöffner
	N080-0422-BK-SER		x				
59	N010-1781-CE-SS	x		x		x	Infrared Burner Shelf Assembly Ensemble étagère pour brûleur infrarouge Conjunto de estante del quemador infrarrojo Infrarot- Brennerregal Montage
	N010-1781-CE-MK		x		x		
60	N335-0098-M06	x		x		x	Side Burner Lid Couvercle du brûleur latéral Tapa del quemador lateral Seitenbrenner- Deckel
	N335-0098-BK1TX		x		x		

	Part # Partie # Parte # Teil #	RPS425	425-PHM	RPS525	525-MK	RPS625	Description Description Descripción Beschreibung
61	N305-10001280	x	x	x	x	x	Wavy Grid Grille ondulée Parrilla onculada Gewelltes Raster
62	N010-1428	x	x	x	x	x	Infrared Burner Brûleur infrarouge Queimador infrarrojo Infrarot-Brenner
63	N500-0039K	x	x	x	x	x	Plate Assiette Placa Platte
64	N240-0026	x	x	x	x	x	Electrode Électrode Electrodo Elektrode
65	N510-0013	x	x	x	x	x	Rectangular Bumper Pare-chocs rectangulaire Tope rectangular Rechteckiger Stoßfänger
66	N080-0358	x	x	x	x	x	Drip Pan Bracket Support de lèchefrite Soporte de bandeja de goteo Halterung für Tropfschale
67	N710-0063	x	x	x	x	x	Drip Pan Bac d'égouttage Bandeja de goteo Auffangwanne
68	N510-0002	x	x	x	x	x	Bumper Pare-chocs Tope Stoßstange
69	N570-0128 N570-0128-BK4FL	x	x	x	x	x	Screw Vis Tornillo Schraube
70	N450-0053	x	x	x	x	x	Nut Écrou Tuerca Nuss
71	N450-0049	x	x	x	x	x	Nut Post Postes d'écrous Poste de tuerca Nuss-Post
72	N555-0091	x	x	x	x	x	Pivot Rod Tige pivotante Varilla pivotante Drehzapfen
73	N485-0021	x	x	x	x	x	Pin Épingle Clavija Stift

	Part # Partie # Parte # Teil #	RPS425	425-PHM	RPS525	525-MK	RPS625	Description Description Descripción Beschreibung
74	N010-1775-30-SS	x					Control Panel Assembly Assemblage du panneau de contrôle Emsamblaje del panel de control Montage des Bedienfelds
	N010-1775-50-SS	x					
	N010-1775-30-MK		x				
	N010-1775-50-MK		x				
	N010-1776-30-SS			x			
	N010-1776-50-SS			x			
	N010-1776-30-MK				x		
	N010-1776-50-MK				x		
	N010-1777-30-SS					x	
	N010-1777-50-SS					x	
75	N010-10001935	x	x				Wire Harness Assemblage du faisceau de câbles Mazo de cables Kabelbaum
	N010-1052LY			x	x		
	N010-1104LY					x	
76	N720-0044	x	x	x	x	x	Connector Connecteur Conector Anschluss
77	N660-0008LY	x	x	x	x	x	Switch Interrupteur Interrupitor Schalter
	N660-0011LY		x		x		
78	N160-0053	x	x	x	x	x	Flex Line Clip Clip pour ligne flexible Clip de línea flexible Flex Line Clip
79	N380-0040	x		x		x	Small Knob Petit bouton Perilla pequeña Kleiner Knopf
	N380-0040-BK		x		x		
80	N010-1054LY	x	x	x	x	x	Small LED Bezel Petite lunette LED Bisel LED pequeño Kleine LED-Linnette
	N387-0014-BK		x		x		
81	N380-0039	x		x		x	Large Knob Grand bouton Perilla grande Großer Knopf
	N380-0039-BK		x		x		
82	N010-1053LY	x		x	x	x	Large LED Bezel Grand cadre LED Bisel LED grande Große LED-Linnette
	N010-1053LY-BK		x		x		

*Alternate burner for Israel.

*Brûleur alternatif pour Israël.

*Quemador alternativo para Israel.

*Alternativer Brenner für Israel.

Accessories Parts List | Liste des pièces accessoires
 Lista de piezas de accesorios | Zubehör Teilleiste

Part # Partie # Parte # Teil #	RPS425R SIB	425R SIB-PHM	RPS525R SIB	525R SIB-MK	RPS625R SIB	Description Description Descripción Beschreibung
62050	x	x	x	x	x	Jet Fire Cleaning Kit Kit de nettoyage Jet Fire Kit de limpieza Jet Fire Jet Fire Reinigungsset
69912	ac	ac	ac	ac	ac	Rotisserie Kit (Europe) Kit de rôtisserie Kit de asador Rotisserie-Bausatz
69913	ac	ac	ac	ac	ac	Rotisserie Kit (UK) Kit de rôtisserie Kit de asador Rotisserie-Bausatz
69915	ac	ac	ac	ac	ac	Rotisserie Kit (Israel) Kit de rôtisserie Kit de asador Rotisserie-Bausatz
61427	ac	ac				Grill Cover Couverture de grill Tapa de parrilla Grillabdeckung
61527			ac	ac		Grill Cover Couverture de grill Tapa de parrilla Grillabdeckung
61627					ac	Grill Cover Couverture de grill Tapa de parrilla Grillabdeckung
56365			ac	ac		Cast Iron Griddle Grille de cuisson en fonte Plancha de hierro fundido Gusseisen Griddle
56425	ac	ac			ac	Cast Iron Griddle Grille de cuisson en fonte Plancha de hierro fundido Gusseisen Griddle
67732	ac	ac	ac	ac	ac	Charcoal/Smoker Tray Bac à charbon/fumoir Bandeja Carbón Ahumador Holzkohle-/Raucherammer
62007	ac	ac	ac	ac	ac	Grease Trays Bacs à graisse Bandejas para Grasa Fettauffangwannen
62020						Drip Pan Liner Doublure du bac de récupération Bandeja de goteo Auffangwanne Liner
62021						
62022						
S82002	ac	ac	ac	ac	ac	Premium Caster Upgrade Kit Kit de mise à niveau des roulettes Premium Kit de mejora de ruedas Premium-Nachrüstatz für Lenkrollen



Exploded View
Vue éclatée
Vista detallada
Explosionszeichnung

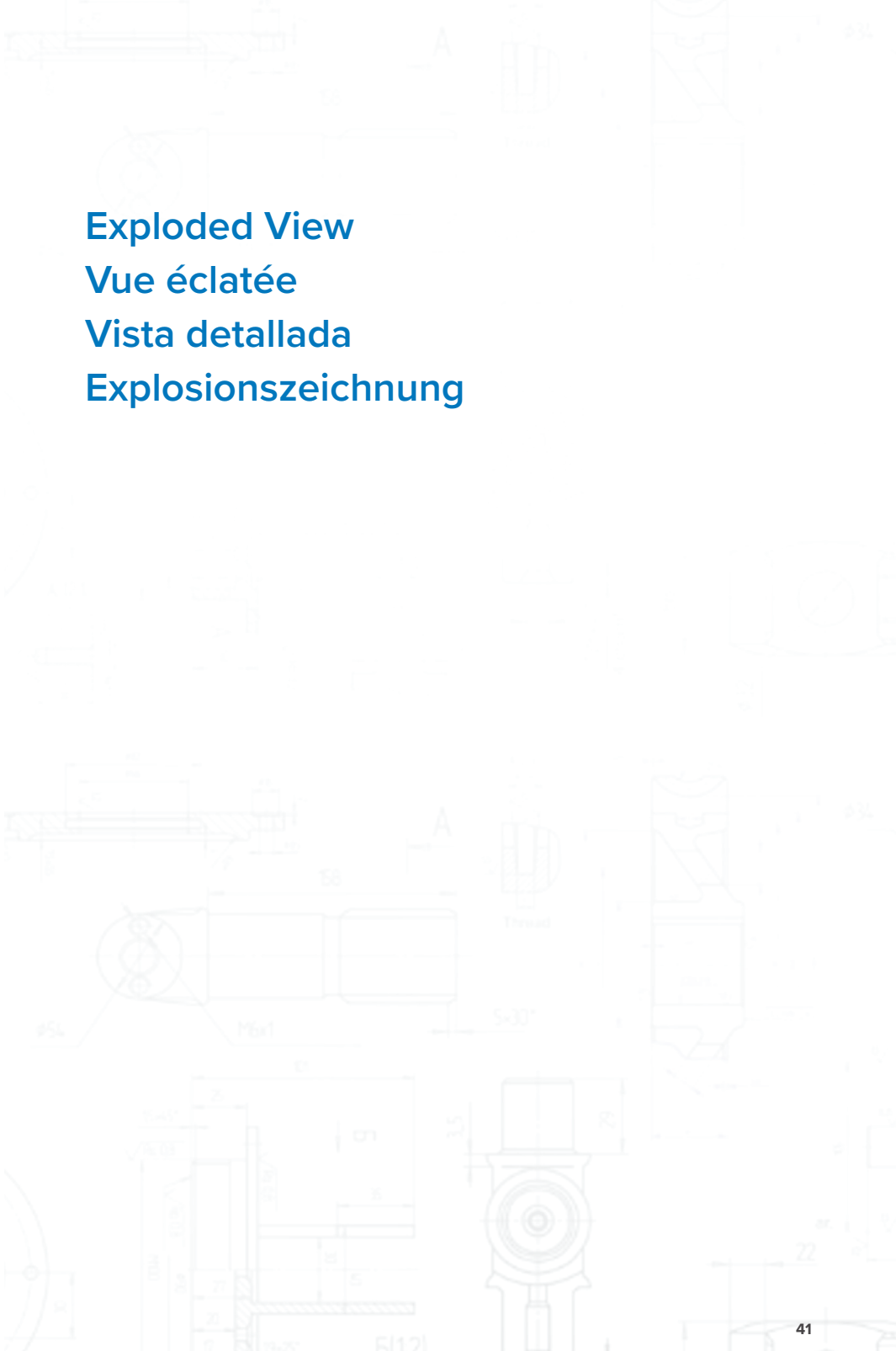

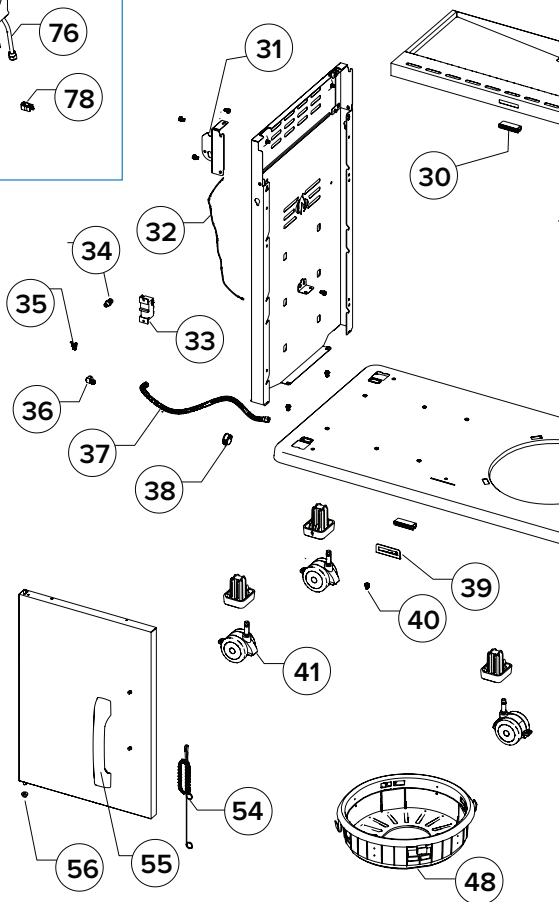
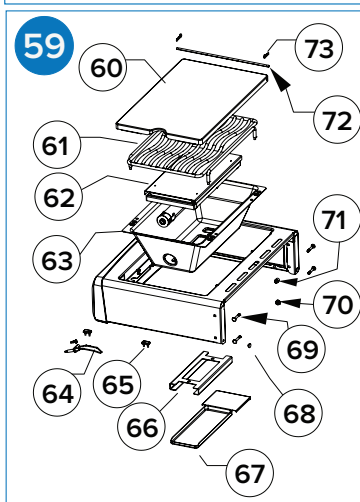
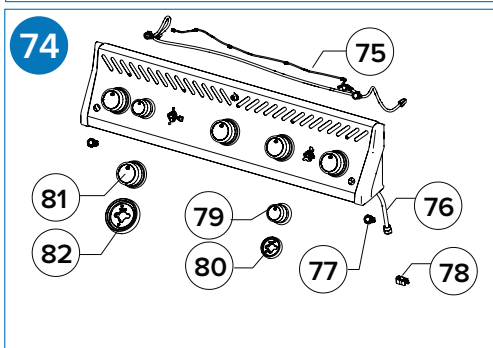
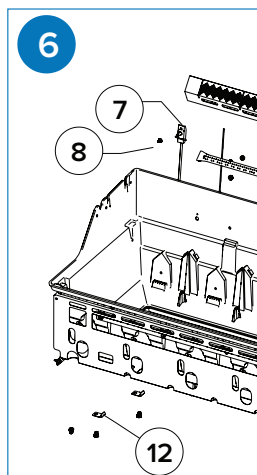
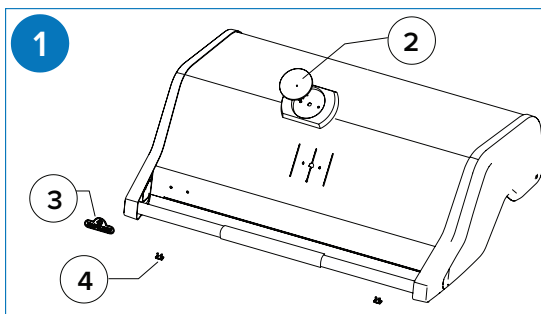

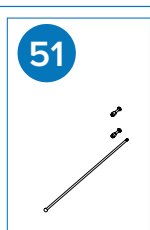
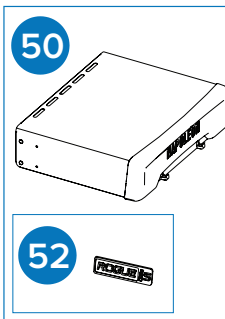
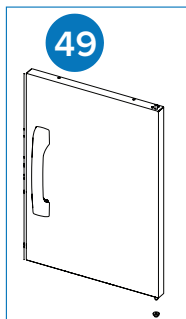
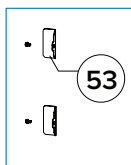
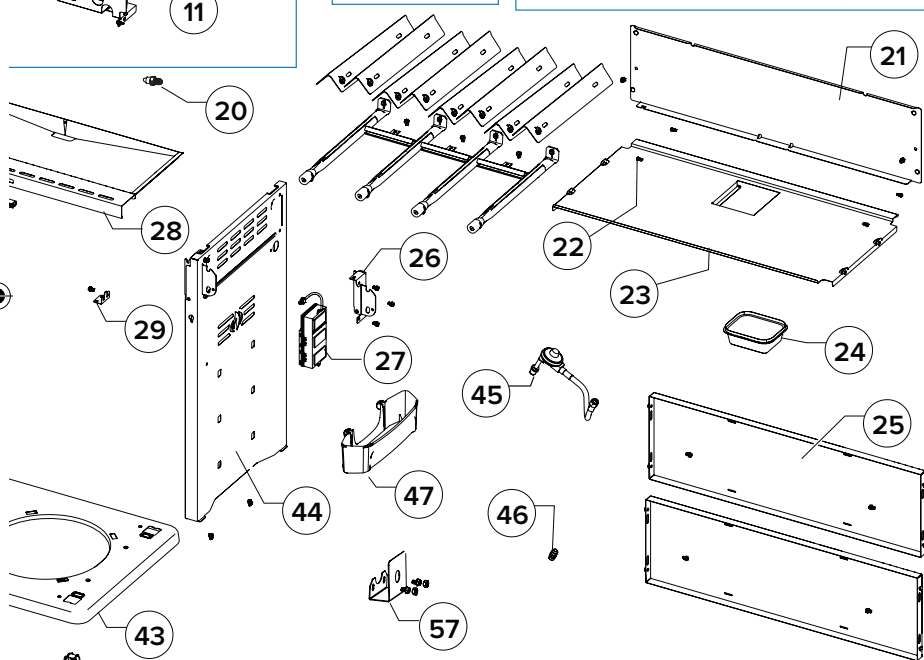
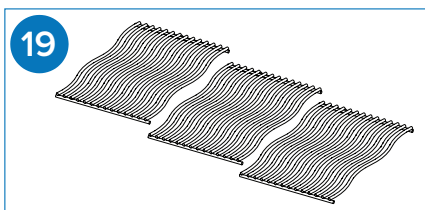
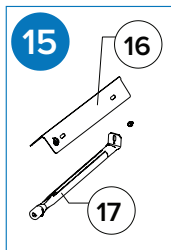
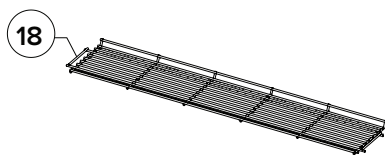
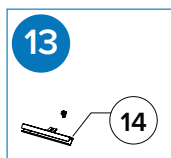
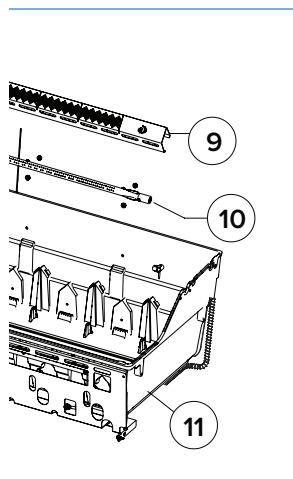

NAPOLEON®

Celebrating over 40 years
delivering home comfort products

Célébrant plus de 40 ans
de produits de confort pour la maison

Celebrando más de 40 años
entregando productos de confort para el hogar

Wir feiern über 40 Jahre
Lieferung von Produkten für den Wohnkomfort



NAPOLEON® products are protected by one or more U.S. and Canadian and/or foreign patents or patents pending.

Les produits de NAPOLEON® sont protégés par un ou plusieurs brevets américains, canadiens et/ou étrangers au par des brevets en instance.

Los productos NAPOLEON® están protegidos por una o más patentes o patentes pendientes en E.U., Canadá y/u otros países.

NAPOLEON®-Produkte sind durch ein oder mehrere US-amerikanische und kanadische und/oder ausländische Patente oder angemeldete Patente geschützt.



**Address | Adresse
Dirección | Adresse**

Wolf Steel Ltd.

De Riemsdijk 22, 4004 LC, Tiel,
The Netherlands
10-12 Home Farm,
Meriden Road, Berkswell,
CV7 7SL, United Kingdom
24 Napoleon Road, Barrie, Ontario,
L4M 0G8, Canada



**Phone | Téléphone
Teléfono | Telefon**

Europe

+31 345 588655

**Online | En ligne
En línea | On-line**

 eu.info@napoleon.com

 www.napoleon.com