

Broil King®



8642-62
9811-63



9815-63



9811-53
9811-52



9815-53





Onward
MANUFACTURING COMPANY
585 KUMPF DRIVE LIMITED
WATERLOO, ONTARIO, CANADA

SINCE 1906

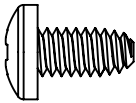
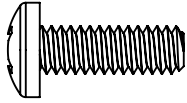

POËÜÖY OEÜÒÁP ÔŠWÖÖÖ

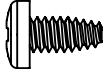
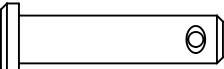
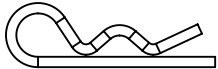
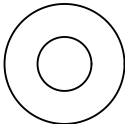
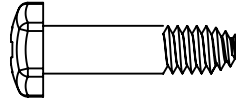
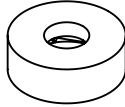
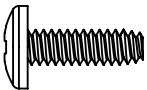

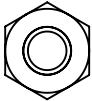
YËGÎÍ  $\varnothing FG$	YËGF€  $\varnothing I$	ÜGFFG  $\varnothing I$
YËJH€  $\varnothing G$	ÜFGHÍ  $\varnothing G$	ÜFGHH  $\varnothing G$
YËGÍÍ  $\varnothing G$	YËFÍÍF  $\varnothing F$	YËFGI  $\varnothing F$
ÜHÍ€J  $\varnothing F$	G€€€Í€€€€  $\varnothing F$	
YËFÍJH  $\varnothing I$		



VUUŠÜÁJÒÚWÖJÖÖ



YËFGGH

Ï€ÏÄ

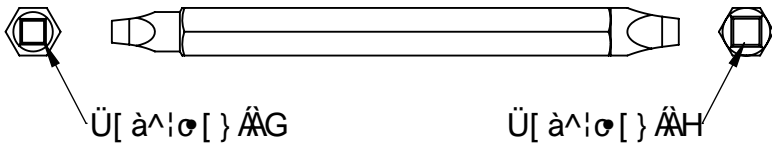

%

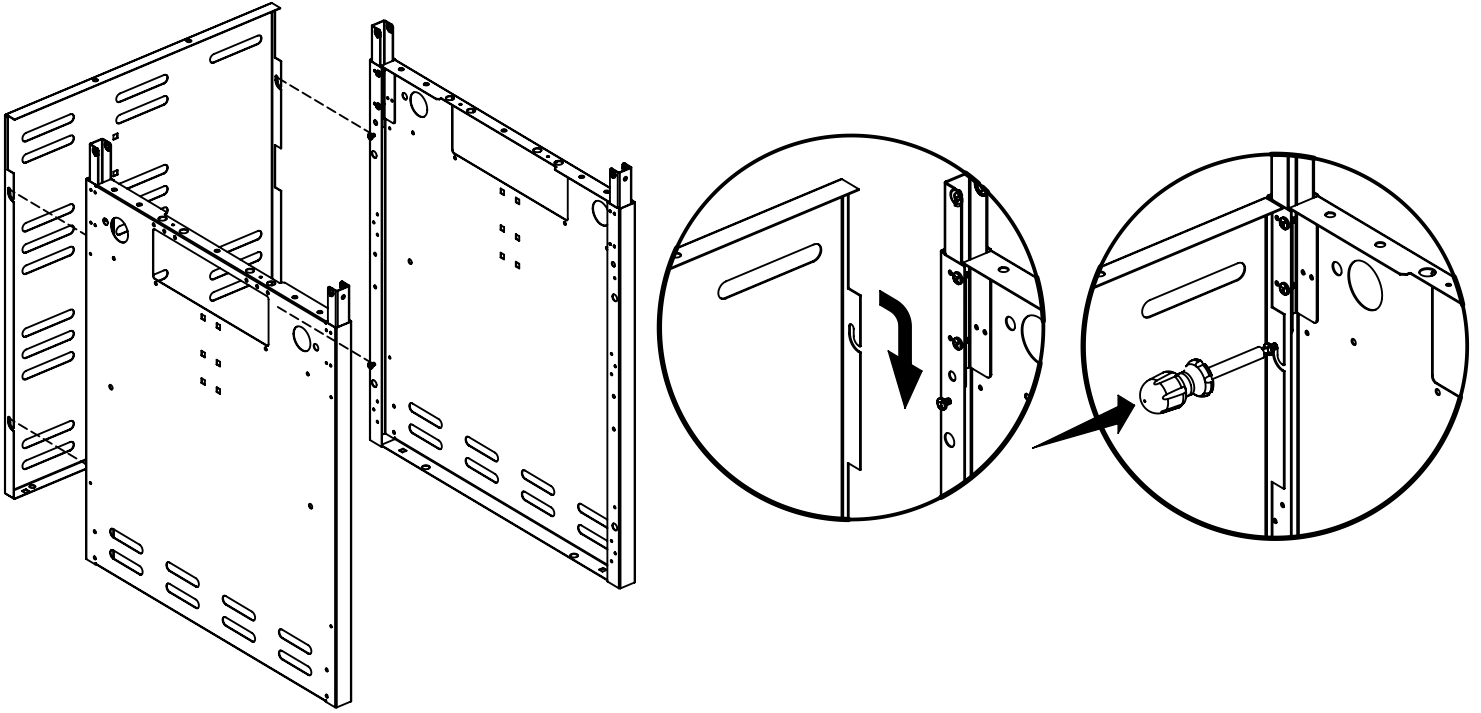

&

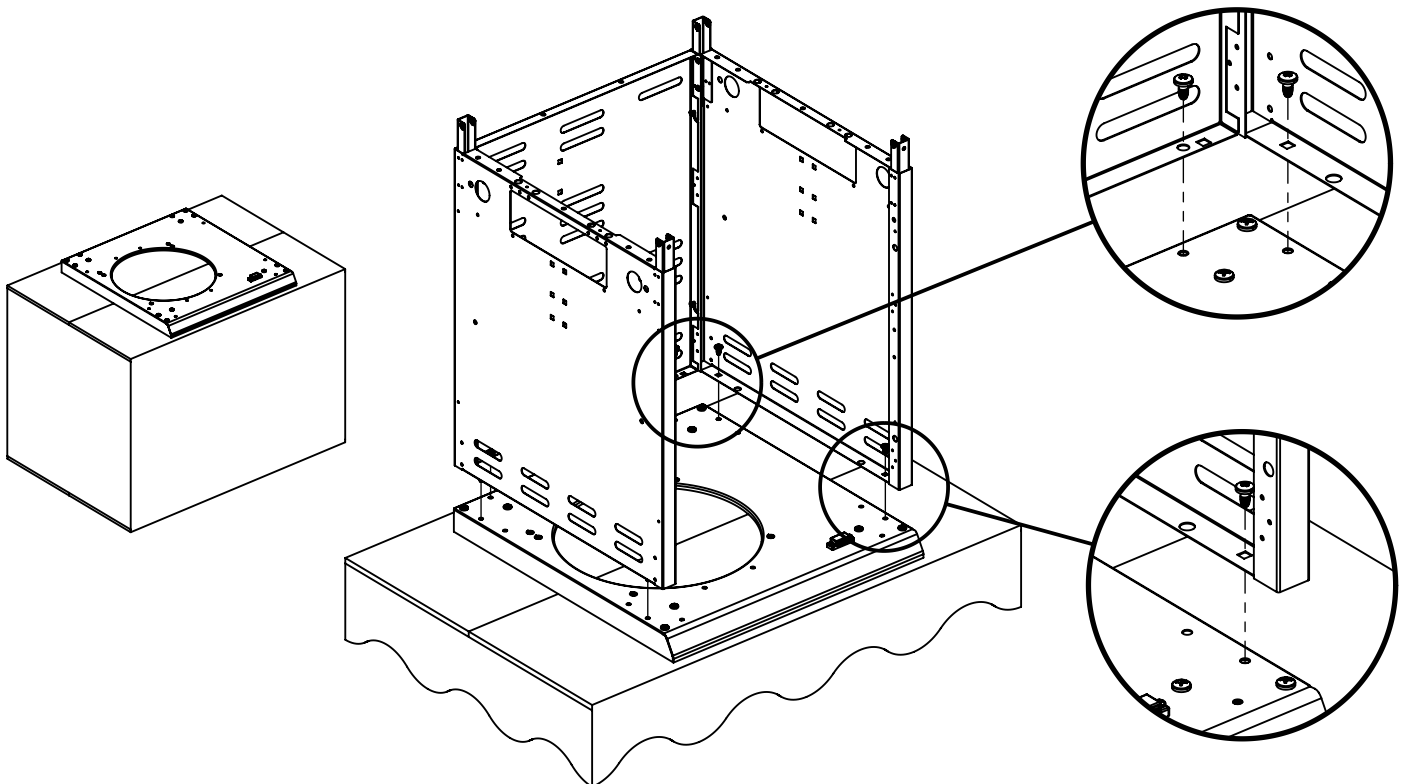
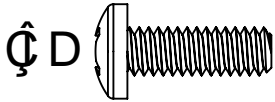

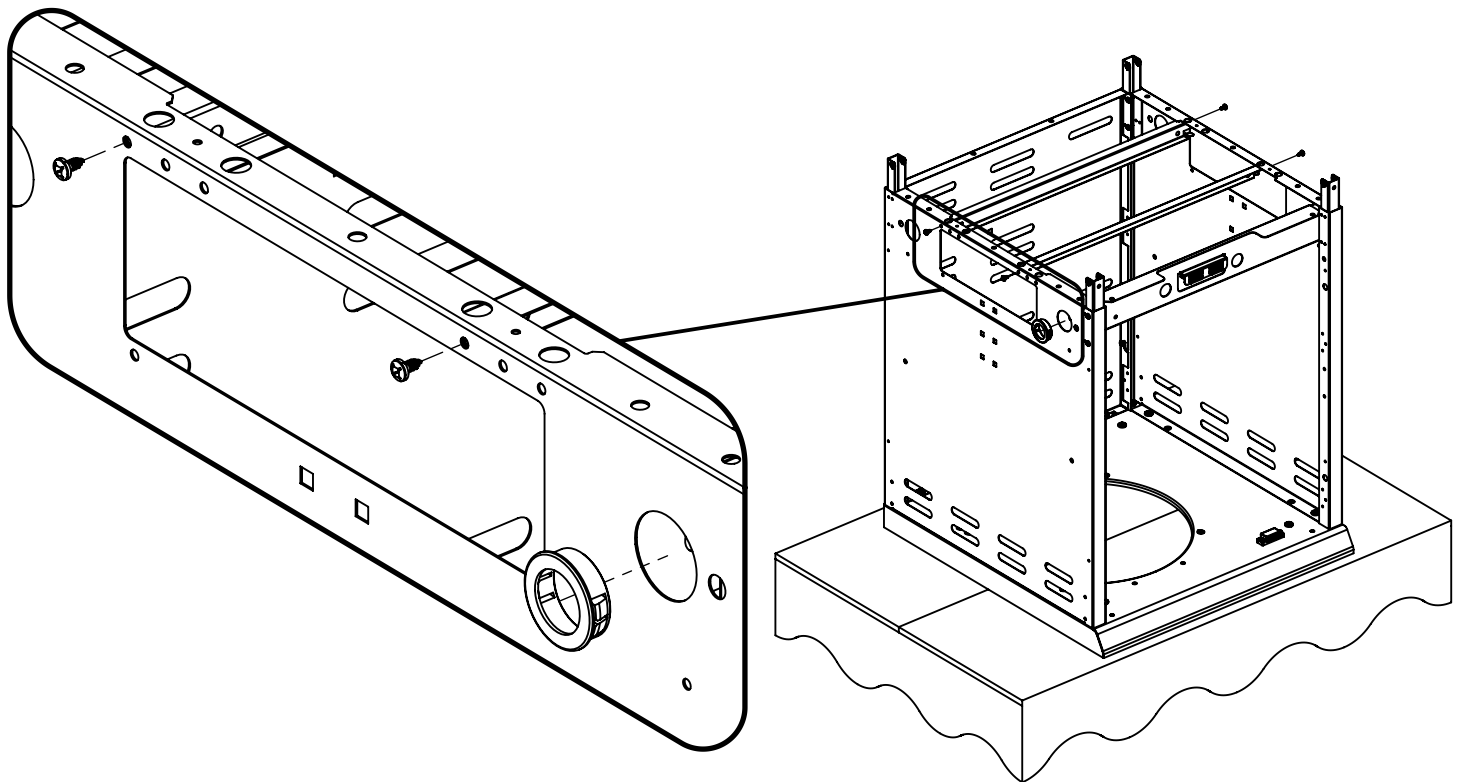
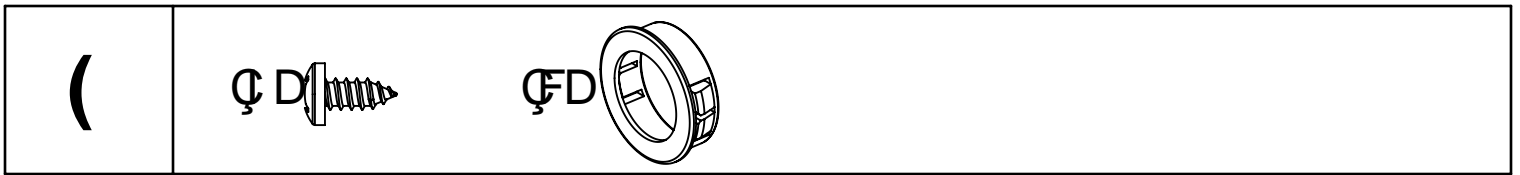
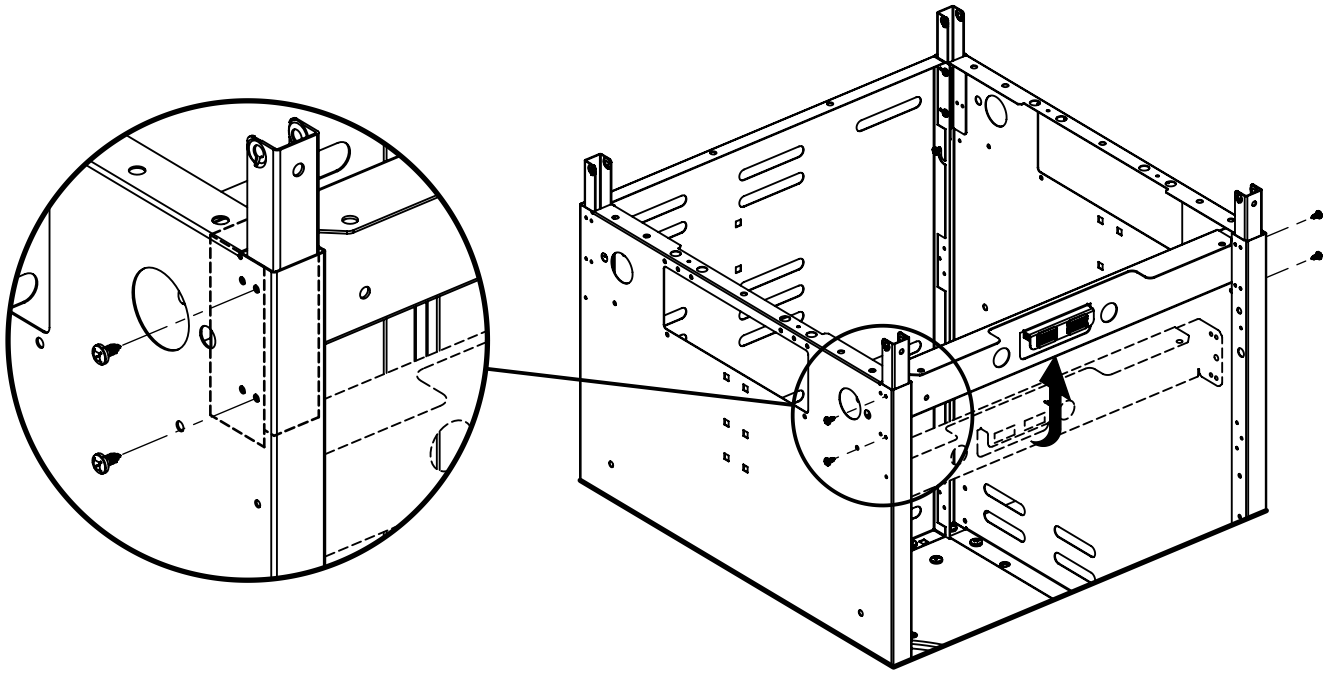
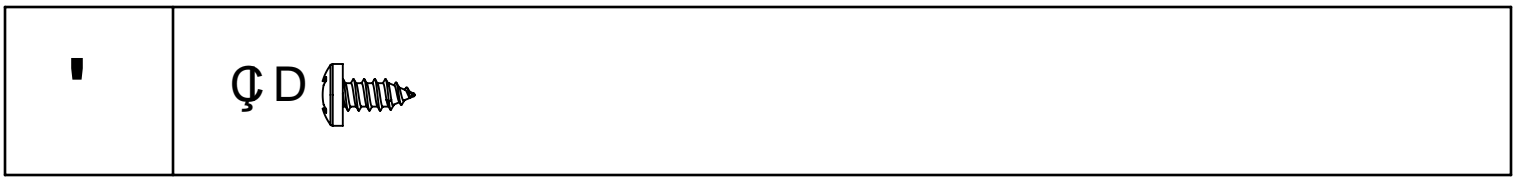

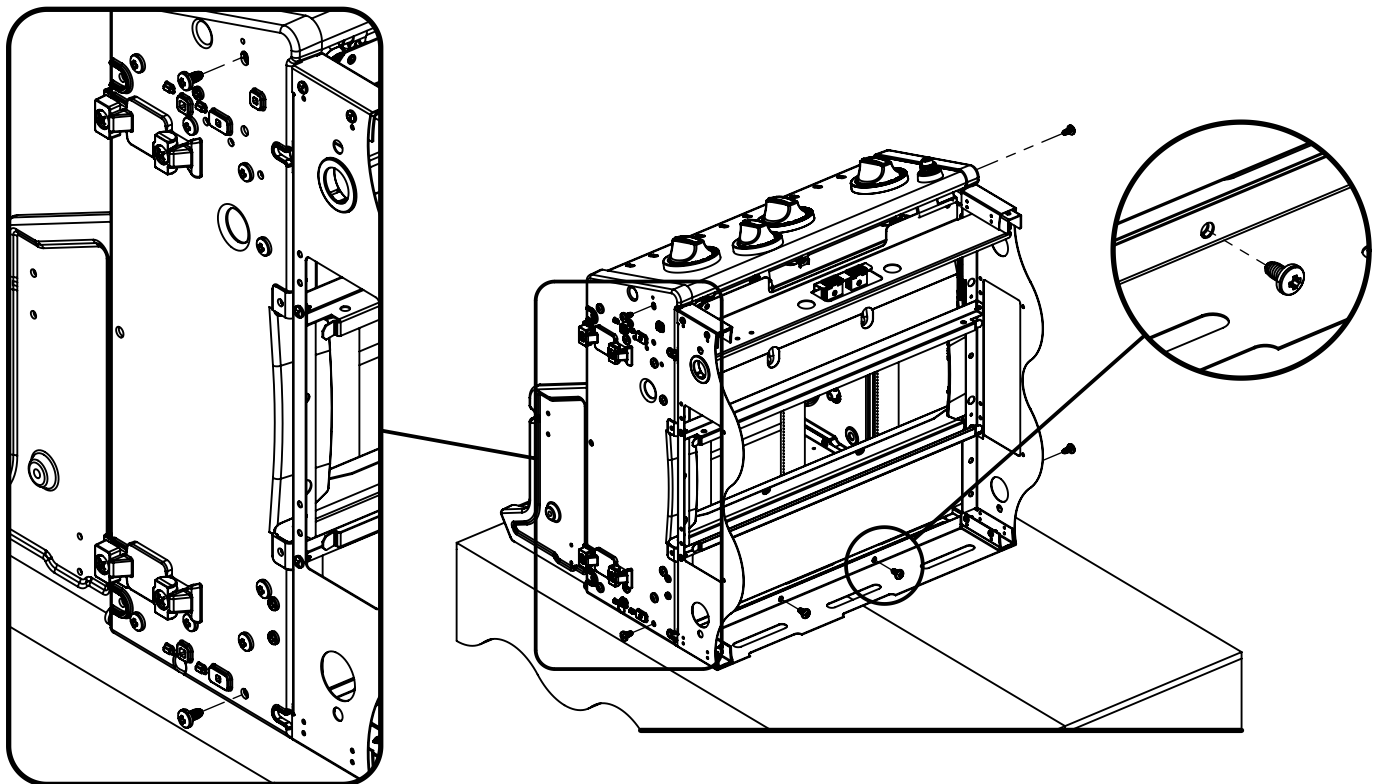
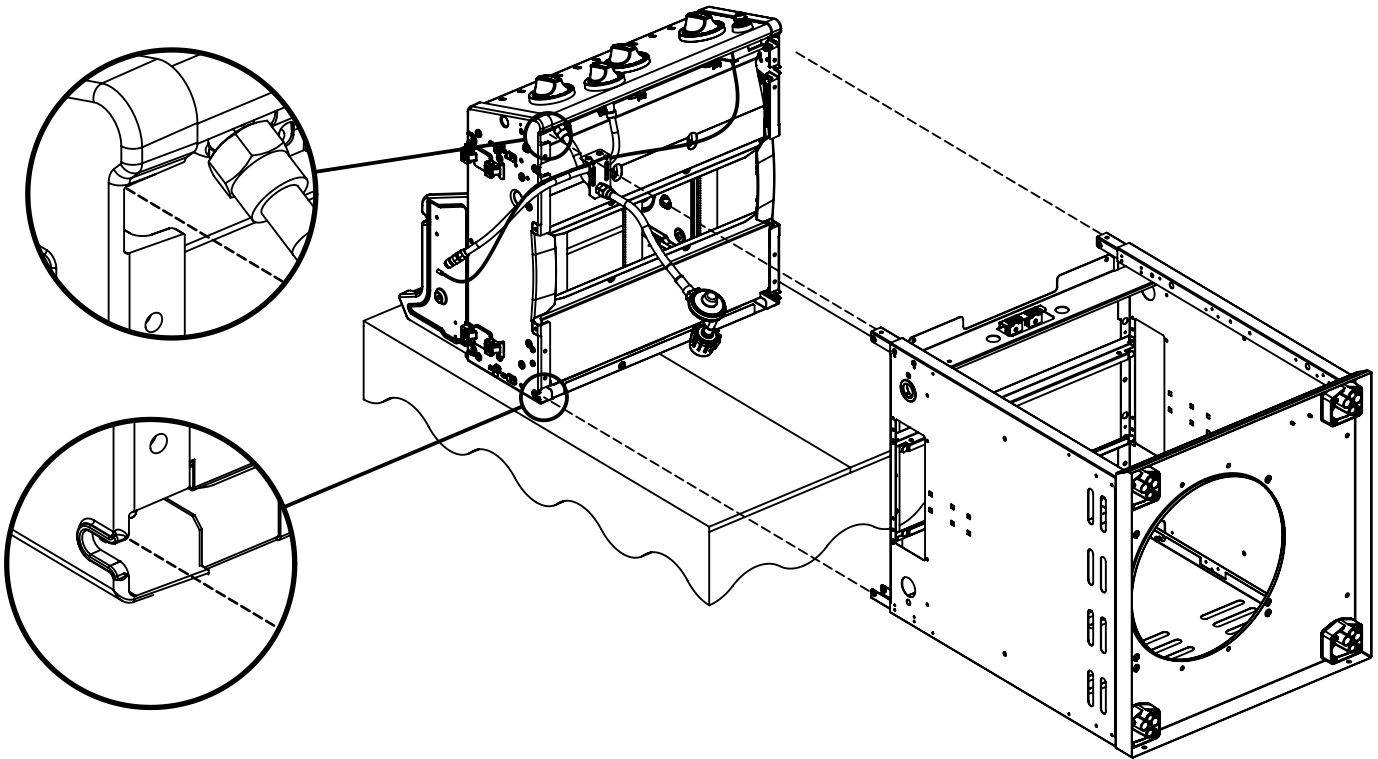
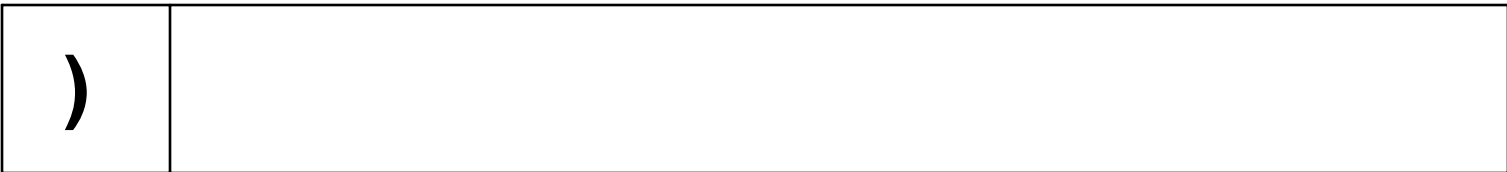

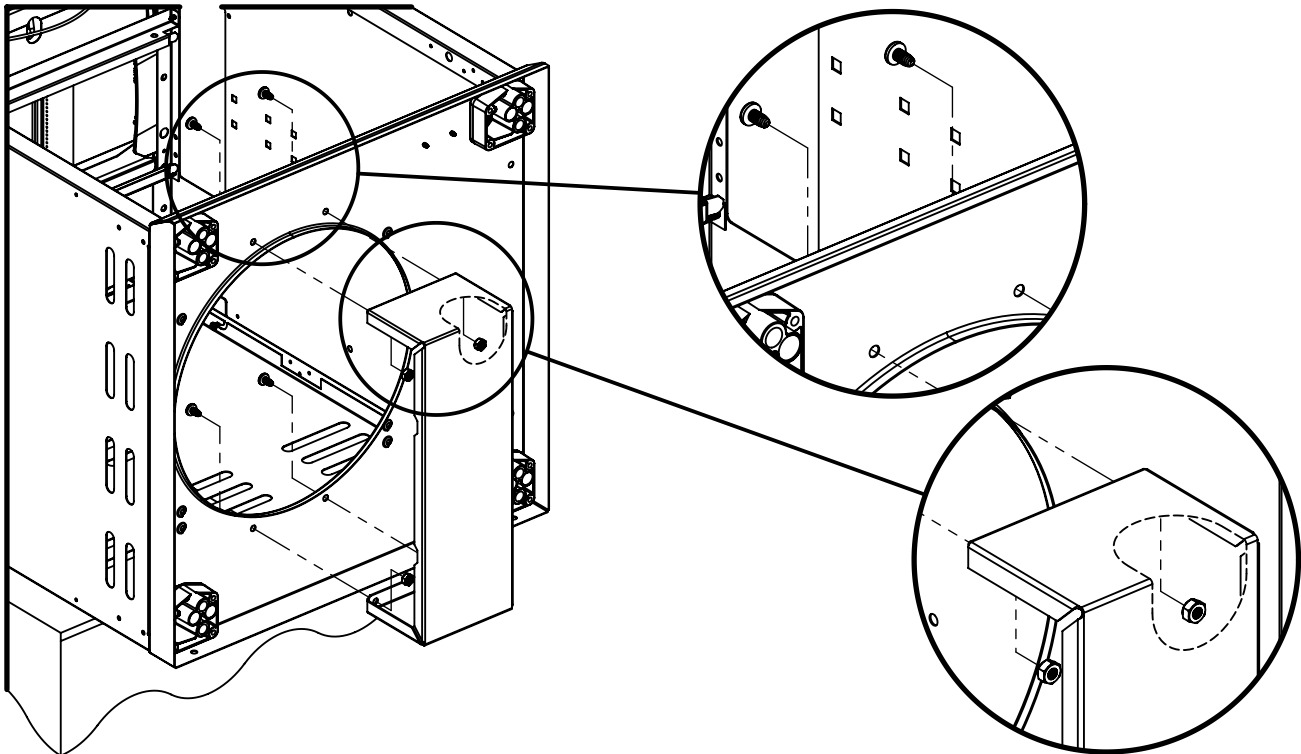
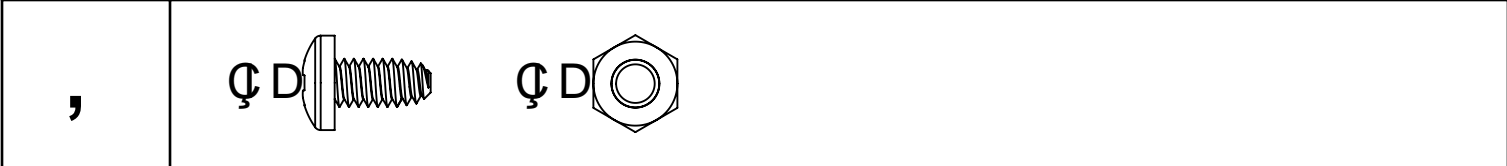
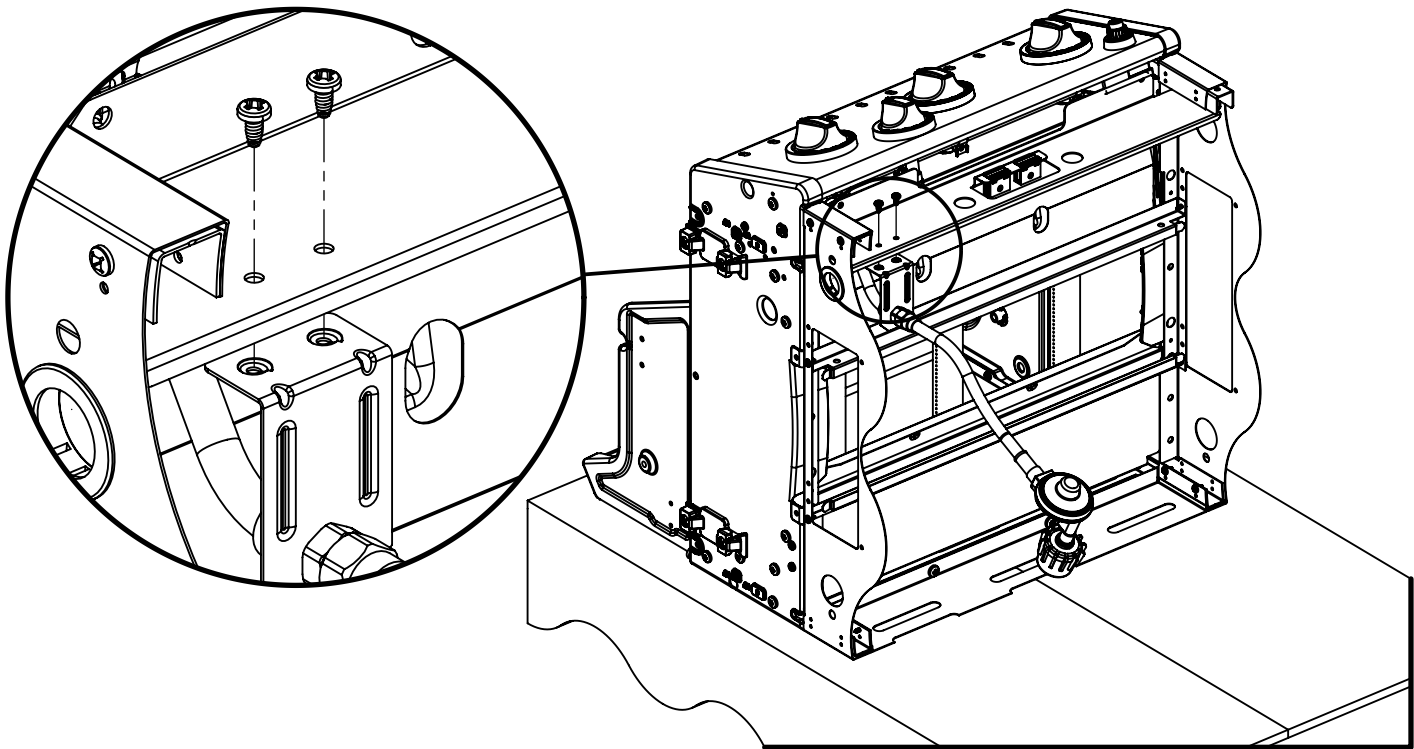
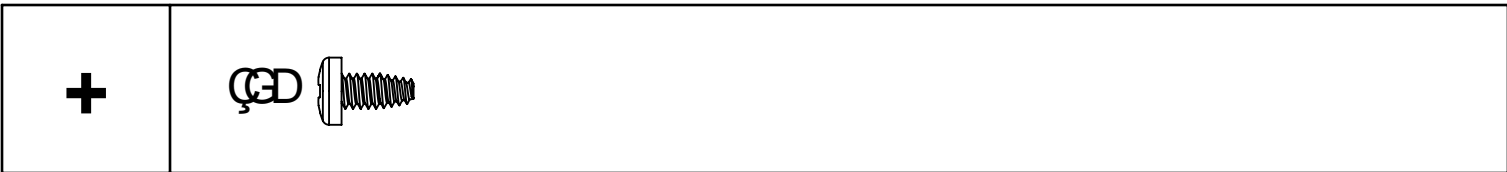

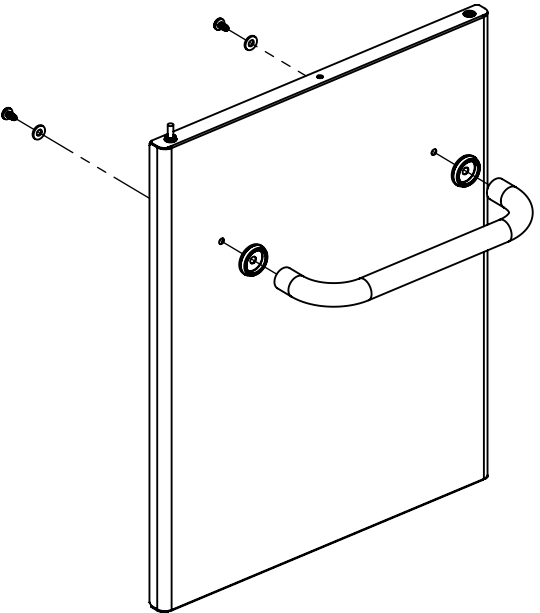
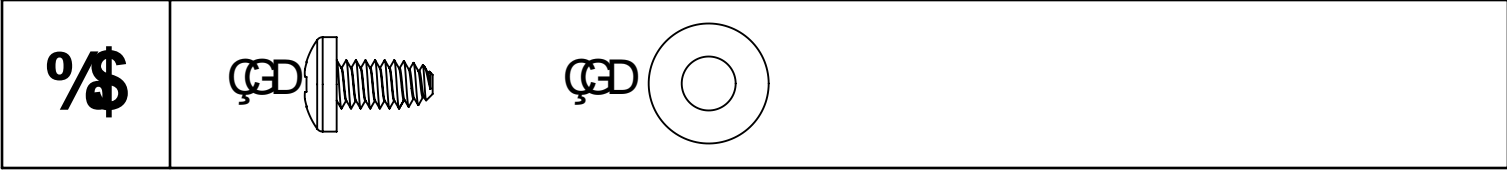
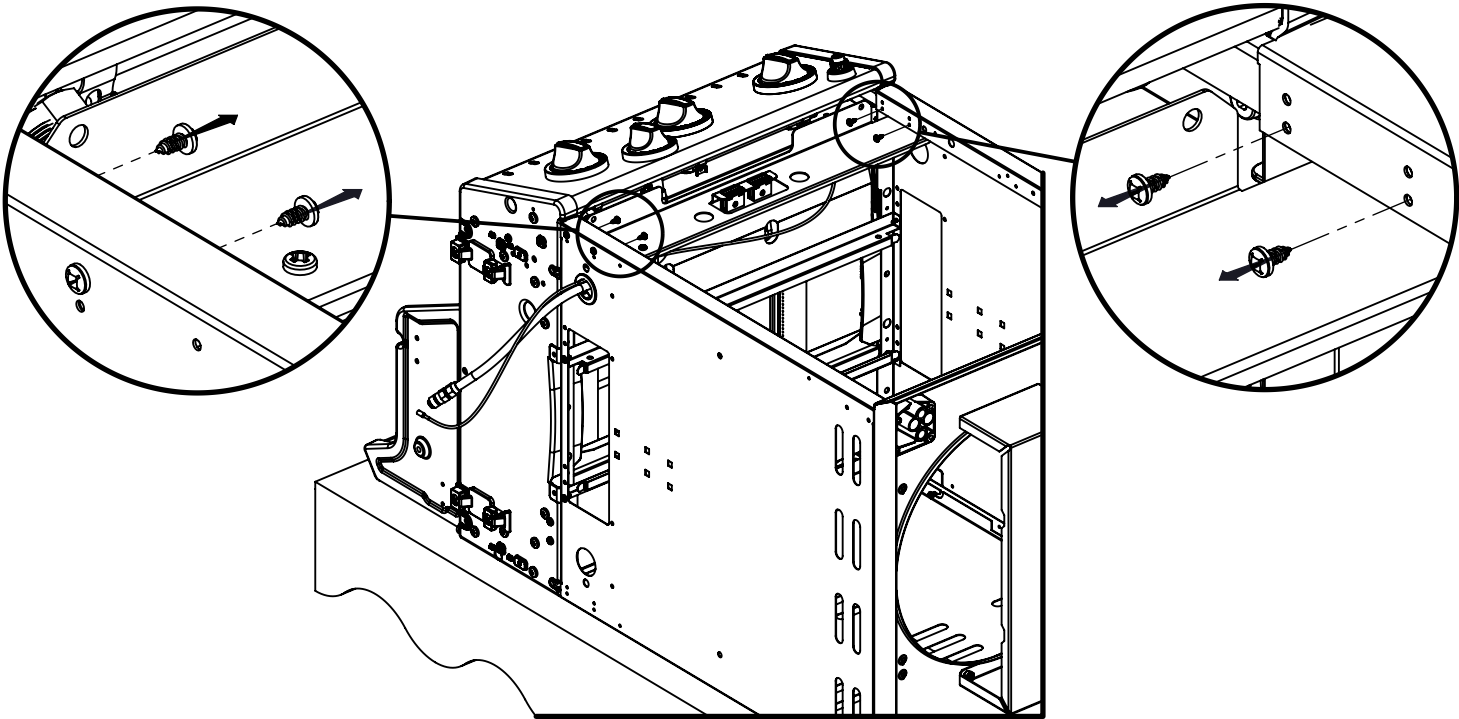
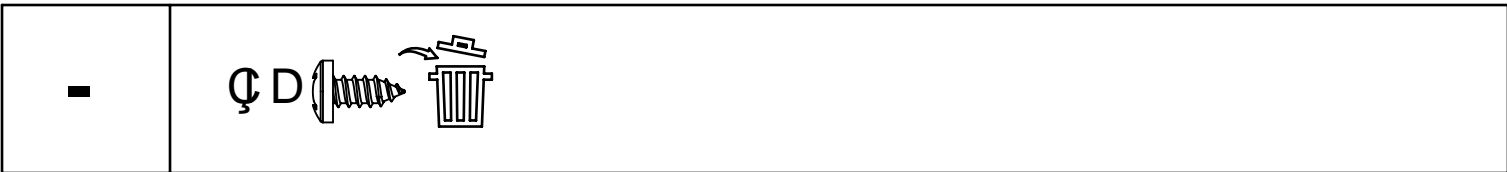

%%

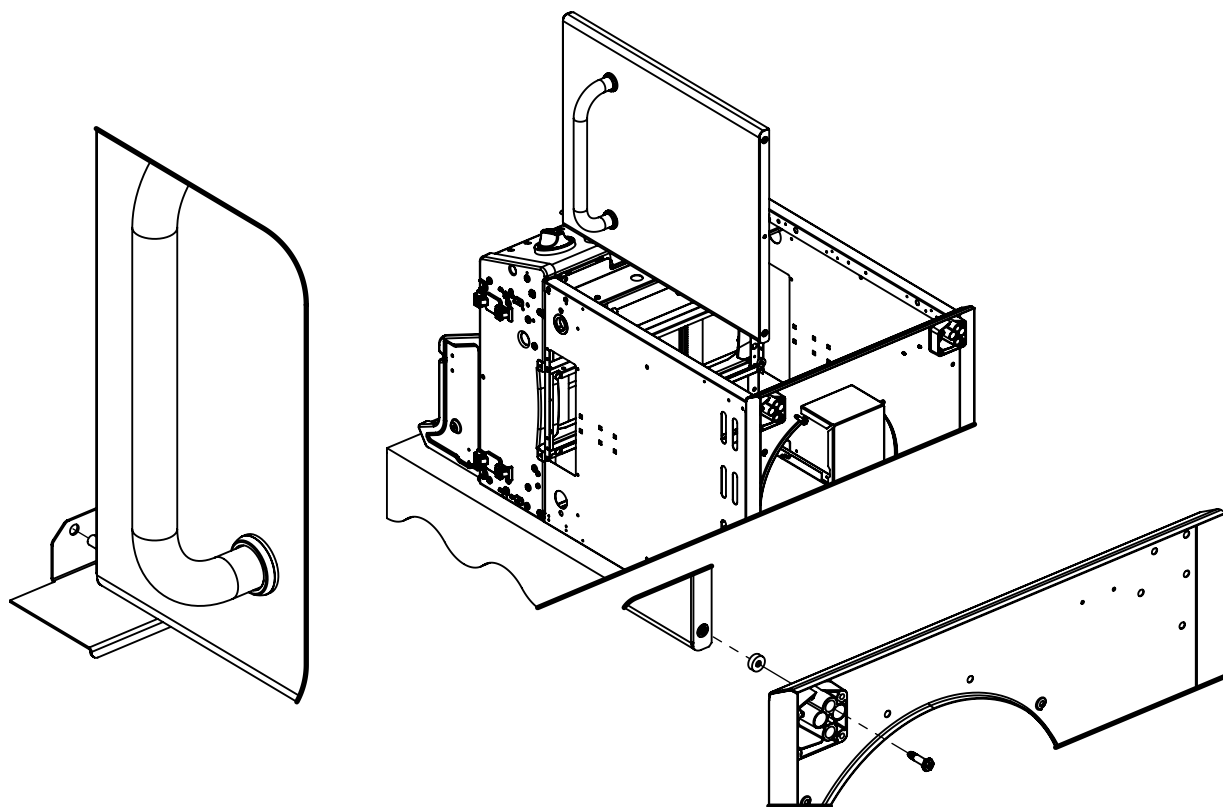
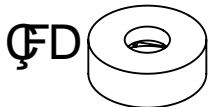
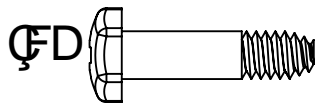

%&

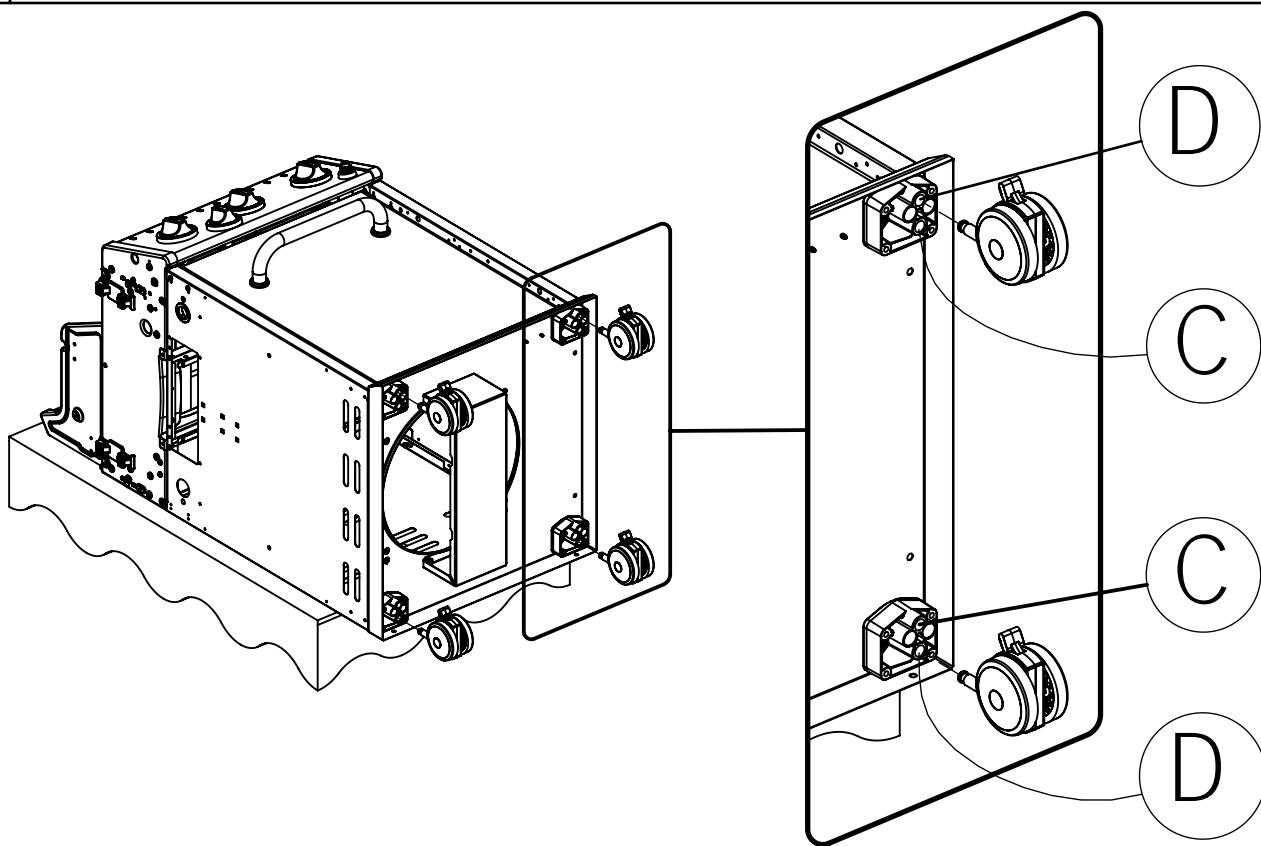

%

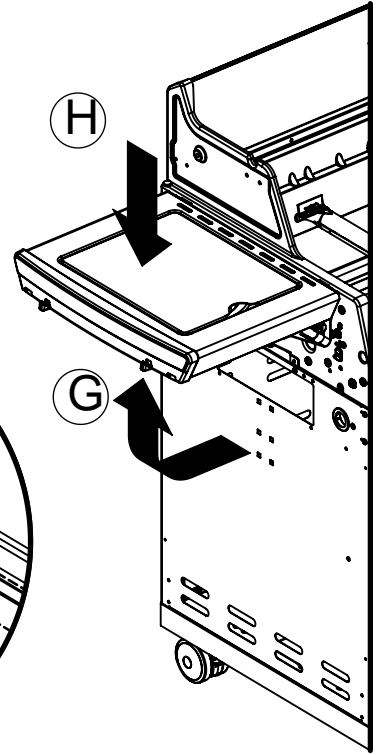
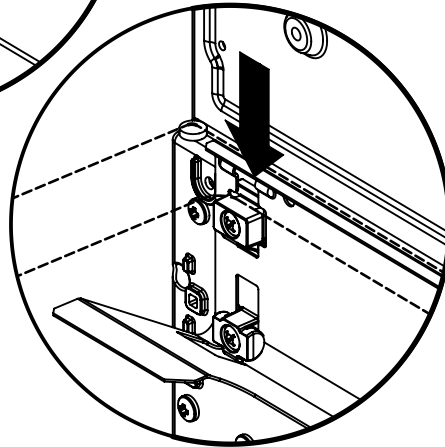
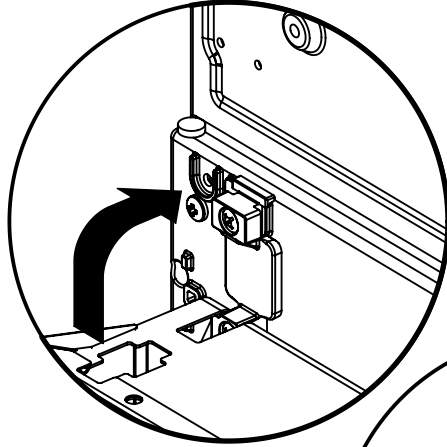
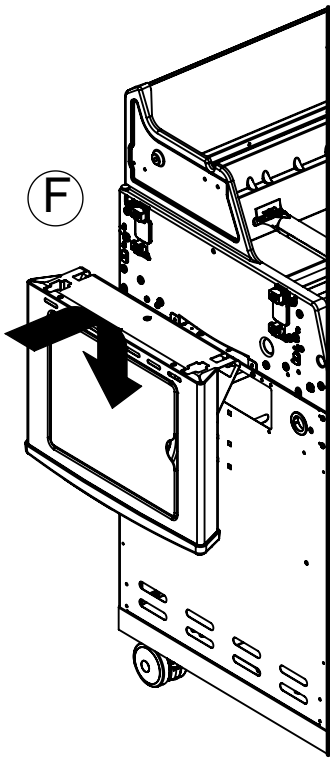

%

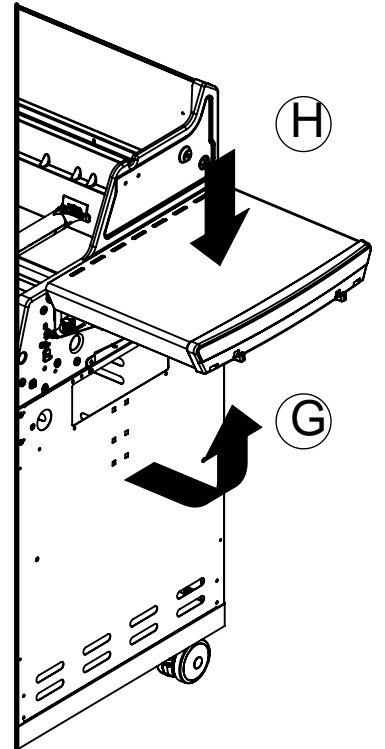
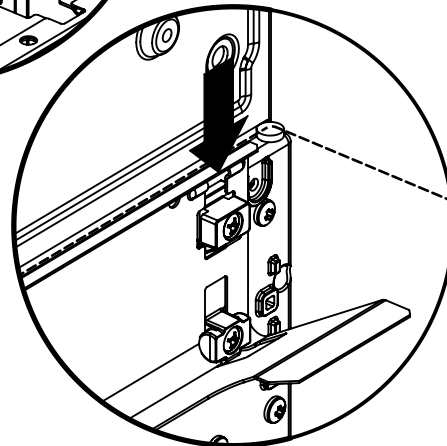
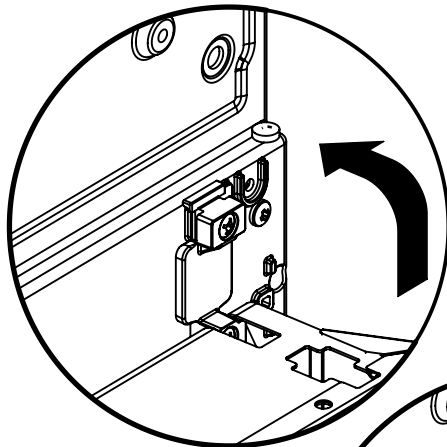
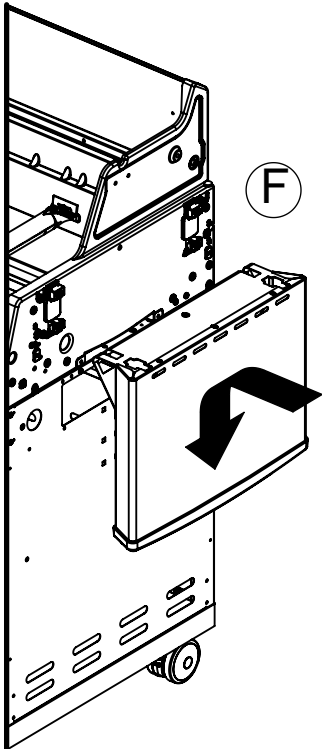

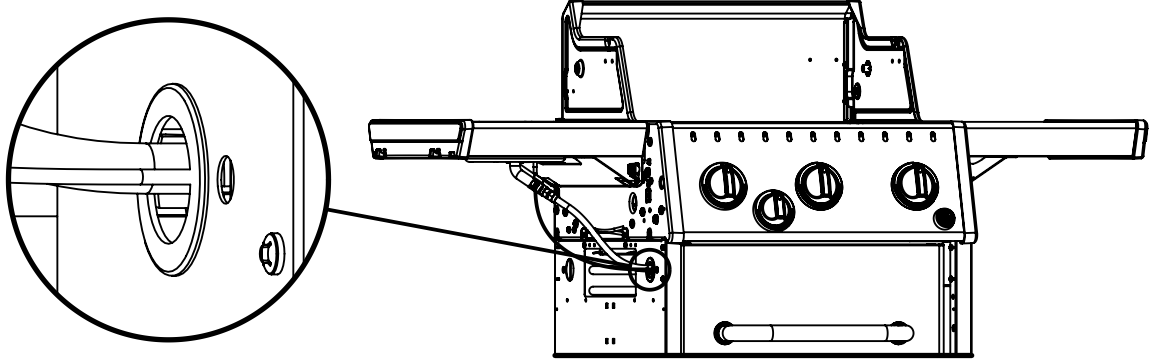
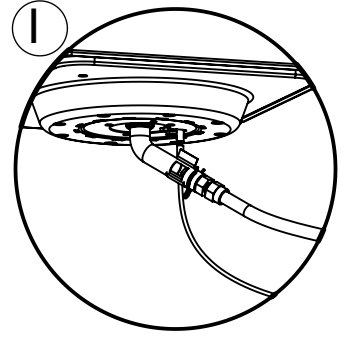
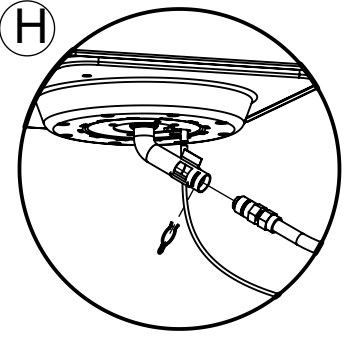
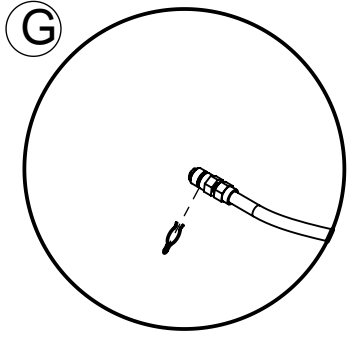
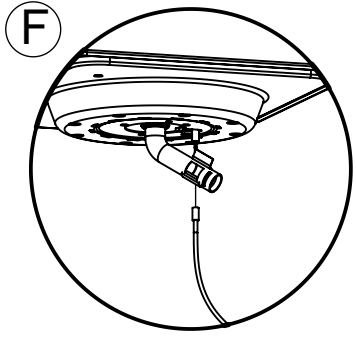
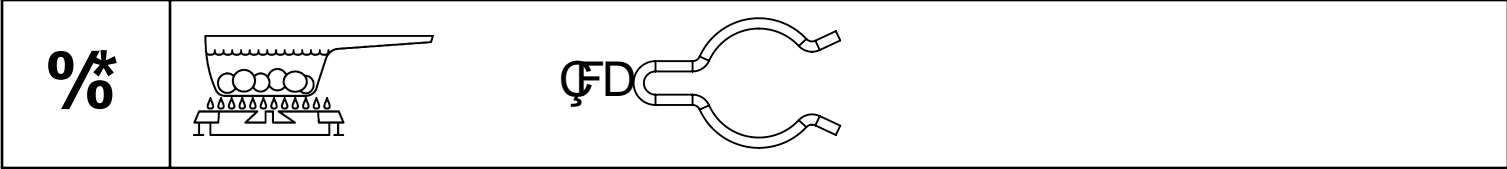
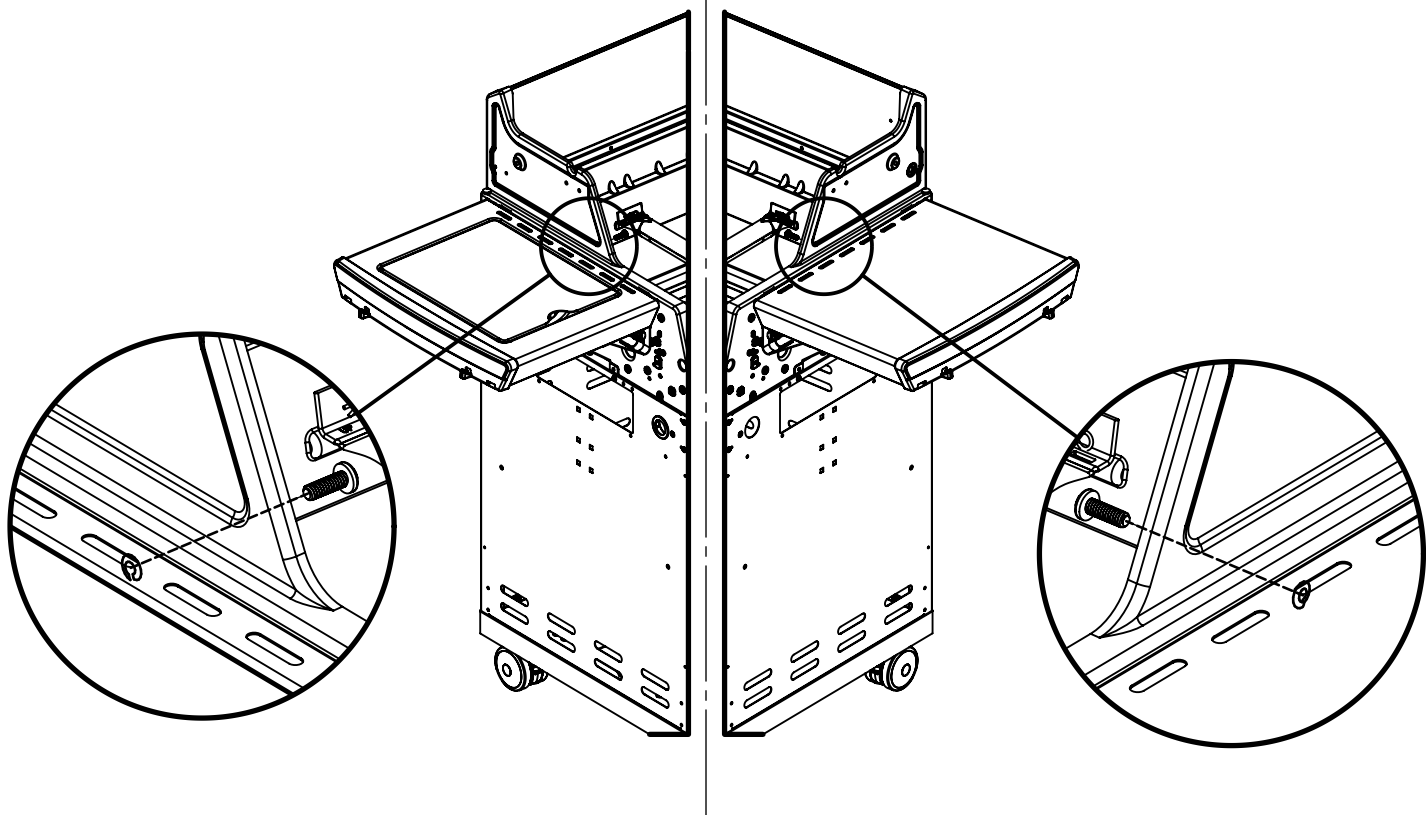

0/d

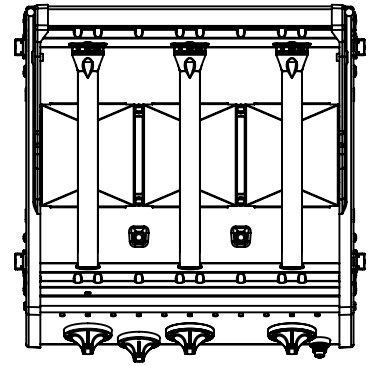
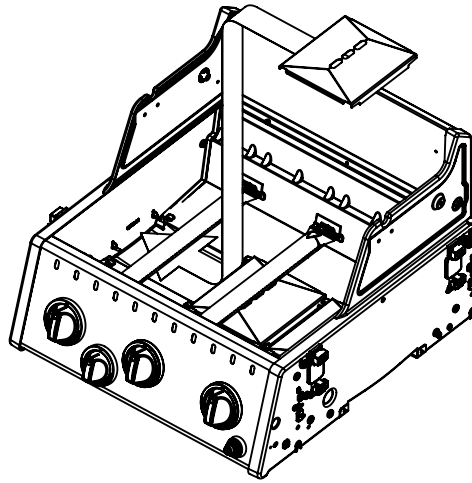
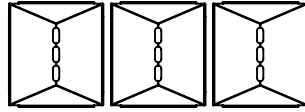
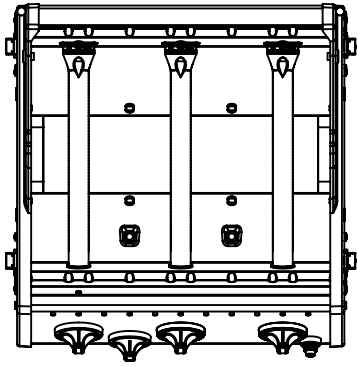

0/9

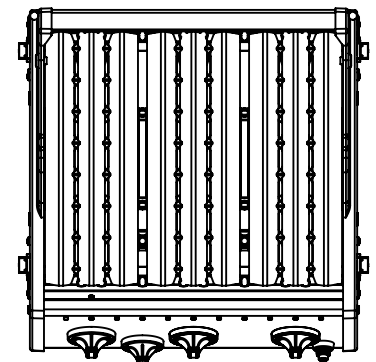
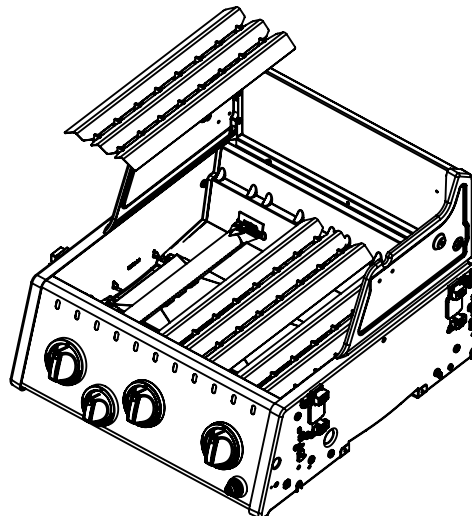
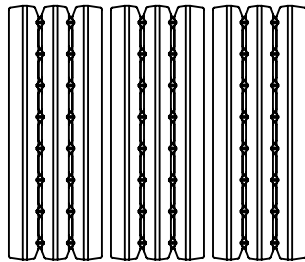
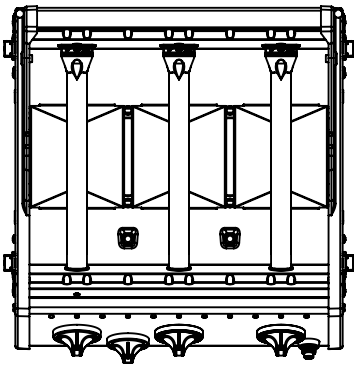

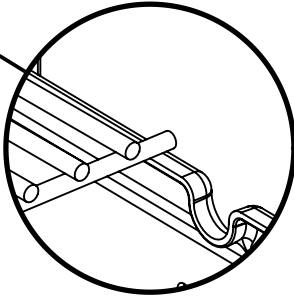
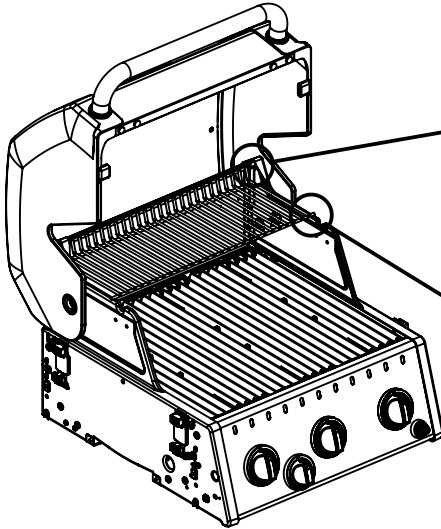
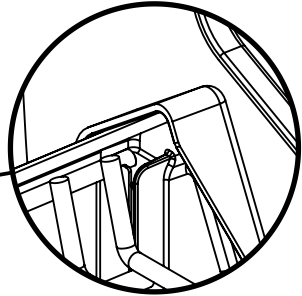
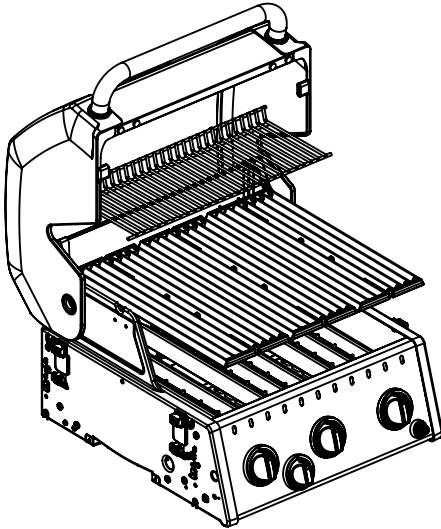
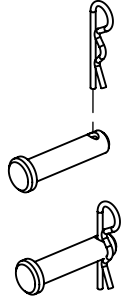
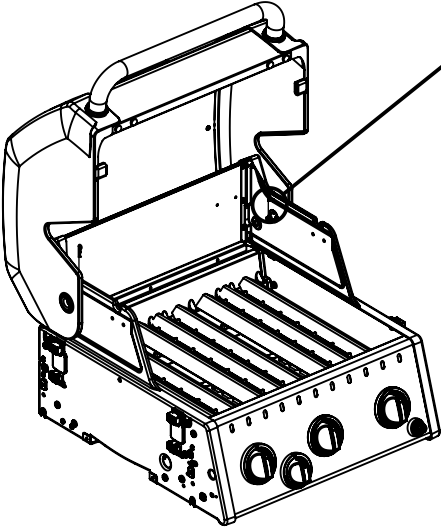
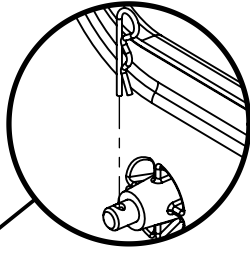
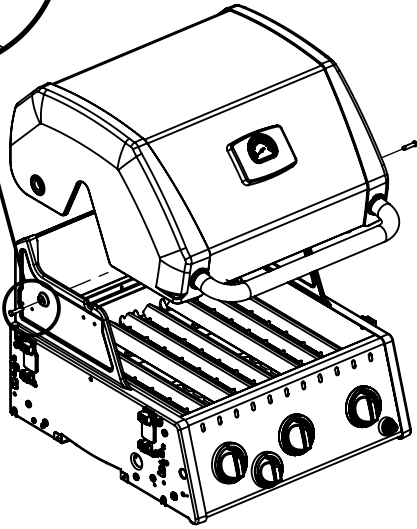
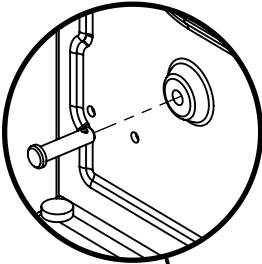
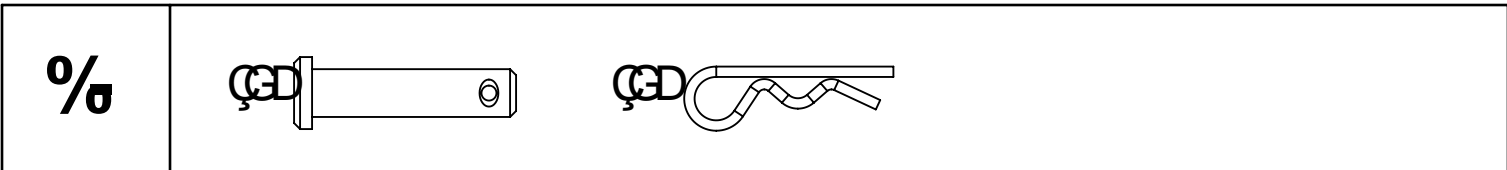

&%

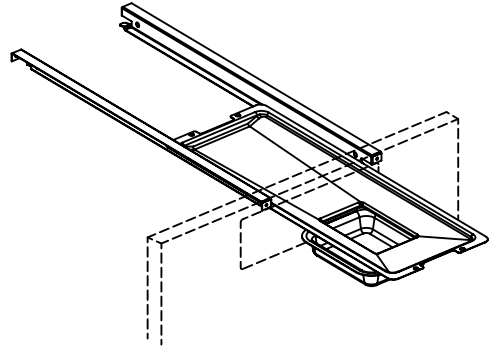
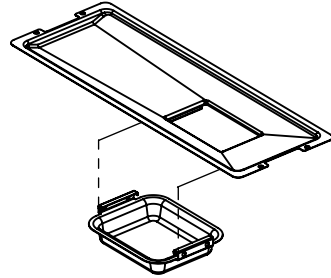
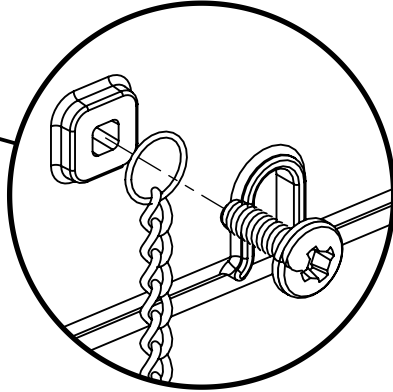
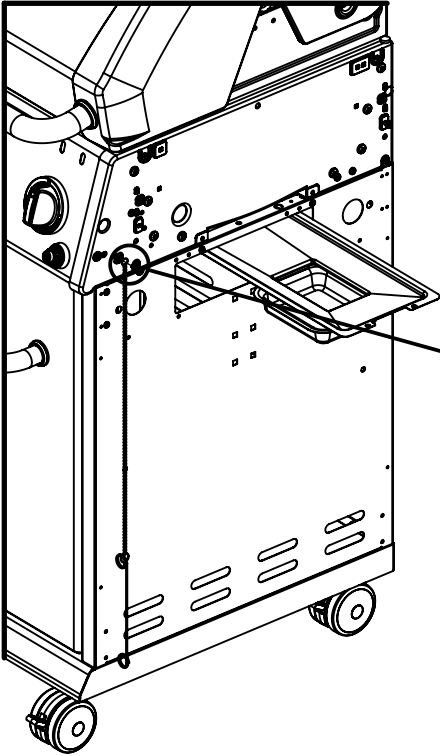
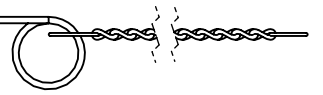
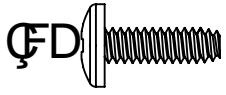

&&

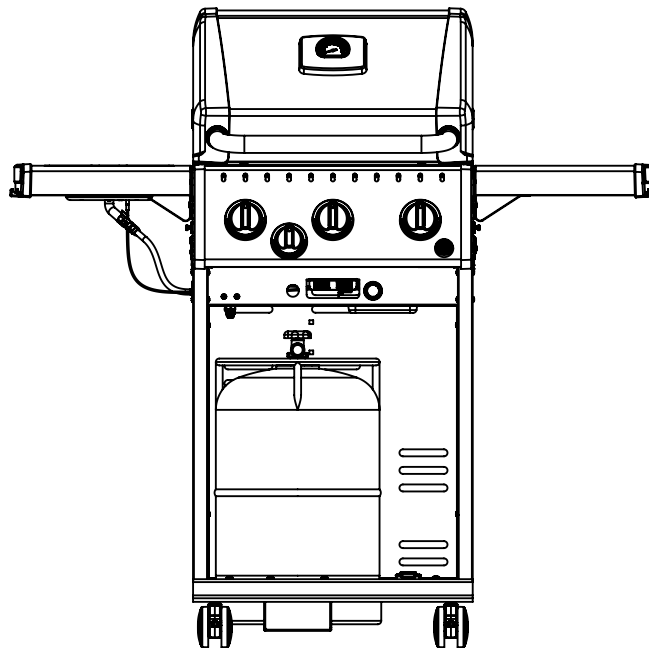

KEY #	ITEM #	DESCRIPTION	9811-52	9811-53	9815-53	8642-62	9811-63	9815-63
1	56004-801	LID	1	1	•	1	1	•
	56004-804		•	•	1	•	•	1
5	10081-BK630	NAMEPLATE	1	1	1	1	1	1
6	10571-6	HEAT INDICATOR	1	1	1	1	1	1
7	24004-12A	HANDLE	1	1	1	1	1	1
8	24009-936	HANDLE BEZEL	2	2	2	2	2	2
10	52104-074	FIREBOX	1	1	1	1	1	1
13	53139-988	SHELF BRACKET	4	4	4	4	4	4
15	52224-024A	COLLECTOR BOX	1	1	1	1	1	1
17	27249-904	GREASE SHEILD	3	3	3	3	3	3
19	10342-E13	ELECTRODE	2	2	2	2	2	2
25	52904-144E	BURNER - MAIN	•	3	3	•	3	3
	52904-144D		3	•	•	3	•	•
28	52023-244	CONTROL COVER	•	•	•	1	1	1
	52023-124		1	1	1	•	•	•
29	59004-012	CONTROL ASSEMBLY	1	•	•	•	•	•
	59004-013		•	1	1	•	•	•
	59004-032		•	•	•	1	•	•
	59004-033		•	•	•	•	1	1
30	S13473-073	HOSE - SIDE BURNER	1	•	•	1	•	•
	S13473-079		•	•	•	•	1	1
	S13473-118		•	•	•	•	•	•
32	10111-15A	HOSE	1	1	1	1	1	1
38	22002-268	CONTROL BEZEL	3	3	3	3	3	3
39	22001-168	CONTROL BEZEL	•	•	•	1	1	1
40	22001-768	CONTROL KNOB	•	•	•	•	•	•
	10472-K431		3	3	3	3	3	3
41	22001-668	CONTROL KNOB	•	•	•	•	•	•
	10472-K231		•	•	•	1	1	1
42	10342-245	ELECTRONIC IGNITOR	1	1	1	•	•	•
	10342-246		•	•	•	1	1	1
44	52209-404	FLAV-R-WAVE ®	3	3	3	3	3	3
45a	52007-181	GRID –162mm	1	1	1	1	1	1
45b	52002-181	GRID – 324mm	1	1	1	1	1	1
46	52004-991	WARMING RACK	1	1	1	1	1	1
47	57054-901	GREASE TRAY	1	1	1	1	1	1
48	52009-901	GREASE PAN	1	1	1	1	1	1
49	21034-991	GREASE TRAY – RAIL	2	2	2	2	2	2
50	51274-131A	DOOR	1	1	•	1	1	•
	51274-134A		•	•	1	•	•	1
55	21106-13	DOOR HANDLE	1	1	1	1	1	1
56	21070-13	HANDLE BEZEL	2	2	2	2	2	2
60	21109-905	CABINET - SIDE PANEL	2	2	2	2	2	2
61	21303-925	CABINET - REAR PANEL	1	1	1	1	1	1
65	51614-235	CABINET - LOWER BASE	1	1	1	1	1	1
66	21039-301	TANK BRACKET	1	1	1	1	1	1
67	51334-211	MAGNET BRACKET	1	1	1	1	1	1
68	57139-13	CONNECTION BRAKET	4	4	4	4	4	4
73	51039-908	CASTER BRACKET	4	4	4	4	4	4
74	10892-286	CASTER	4	4	4	4	4	4
80	50711-111A	SIDE SHELF	2	2	2	1	1	1
82	50711-131A	SIDE SHELF - SIDE BURNE	•	•	•	1	1	1
86	10390-E10E	SIDE BURNER	•	•	•	•	1	1
	10390-E10D		1	•	•	1	•	•
87	53004-271	SIDE BURNER - BODY	•	•	•	1	1	1
88	53000-251	SIDE BURNER - COVER	•	•	•	1	1	1
89	63139-981	SIDE BURNER GRID	•	•	•	1	1	1
92	10342-T21	SIDE BURNER ELECTRODI	•	•	•	1	1	1
100	Y-12220	GROMMET	•	•	•	1	1	1
125	Y-12835	SCREW - #6 X 1/4	•	•	•	2	2	2
127	S21125	SCREW - #8 X 3/8	12	12	12	12	12	12
129	S21124	SCREW - #8 X 1/2	6	6	6	6	6	6
131	S21136	SCREW - #8-32 X 1/2	3	3	3	4	4	4
133	Y-12646	SCREW - SHOULDER #8 X	•	•	•	2	2	2
134	Y-29304	SCREW - #10-24 X 3/8	2	2	2	2	2	2
135	S35094	SCREW - #10-24 X 5/8	1	1	1	1	1	1
136	Y-29310	SCREW - #10-24 X 3/4	2	2	2	2	2	2
140	Y-12865	SCREW - 1/4-20 X 1/2	2	2	2	2	2	2
141	Y-12310	SCREW - 1/4-20 X 3/4	16	16	16	16	16	16
142	Y-11559	SCREW - 1/4-20 X 1	10	10	10	10	10	10
151	Y-11793	NUT - 1/4-20	4	4	4	4	4	4
160	Y-12857	WASHER	2	2	2	2	2	2
169	Y-11230	SIDE BURNER – RETAINEF	•	•	•	1	1	1
170	S21235	HINGE PIN	2	2	2	2	2	2
171	S21233	CLIP	2	2	2	2	2	2
173	10240-20	DOOR HINGE PIN - TOP	1	1	1	1	1	1
175	Y-11551	DOOR SCREW	1	1	1	1	1	1
176	Y-12124	DOOR HINGE COVER	1	1	1	1	1	1
177	Y-12222	MAGNET	1	1	1	1	1	1
178	Y-12223	MAGNET - SNAP IN	1	1	1	1	1	1
181	Y-11231	LID BUMPER - ROUND	4	4	4	4	4	4
182	20005-000	MATCH LIGHT CHAIN	1	1	1	1	1	1
185	S21242	CLIP	3	3	3	3	3	3
186	Y-11544	BURNER SCREW	3	3	3	3	3	3

