

# Broil King®

---

---



BARON 320  
9219-52  
9219-53  
9219-56



BARON 340  
9219-62  
9219-63  
9219-66



BARON 320S  
9215-52  
9215-53  
9215-56



BARON 340S  
9215-62  
9215-63  
9215-66

---

*Onward*  
MANUFACTURING COMPANY







SINCE 1906

1000 EAST MARKET STREET  
HUNTINGTON, INDIANA, 46750, USA

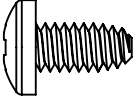

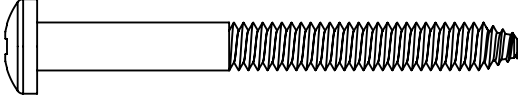
# HARDWARE INCLUDED

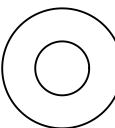
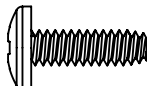
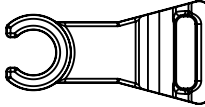
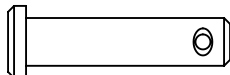
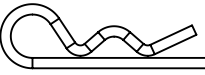

Y-12865		X26	S21125		X12
Y-11562					X4
Y-29310		X4	Y-29304		X2
Y-11793		X4	Y-12857		X2
S35094		X1	Y-12127		X1
S21235		X2	S21233		X2



# TOOLS REQUIRED



Y-31223

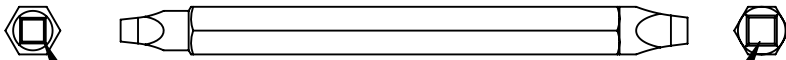

Robertson #2

Robertson #3

7/16"

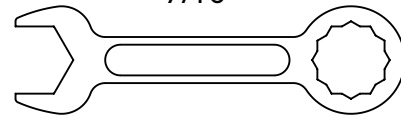

1

(8)

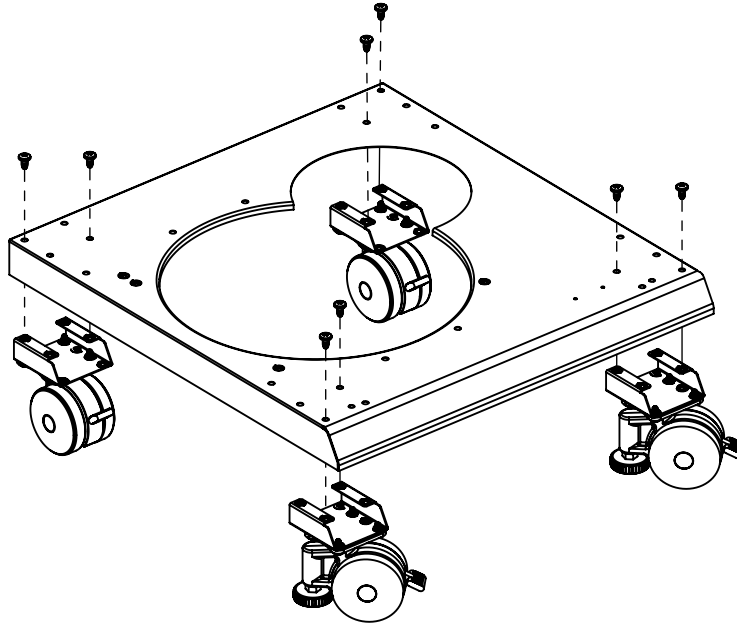
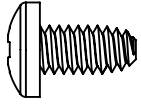

2

(4)

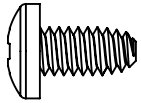

(4)

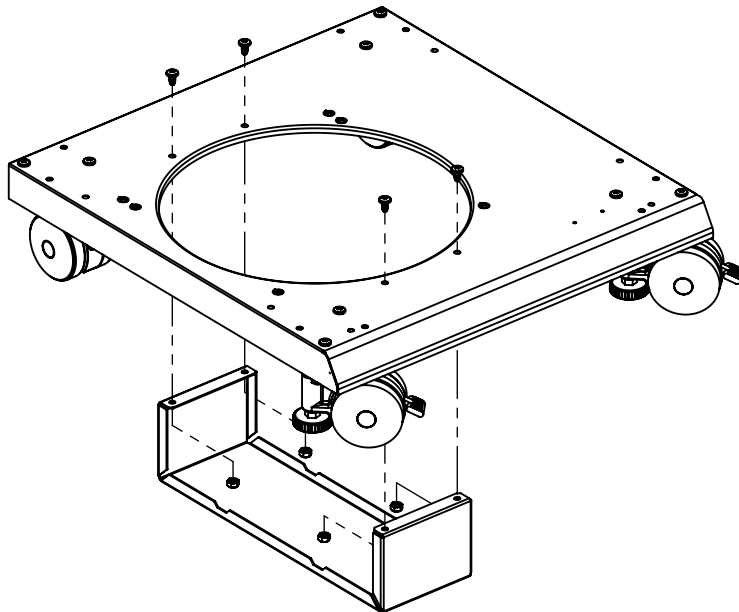
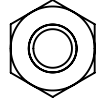

**3**

(4) 

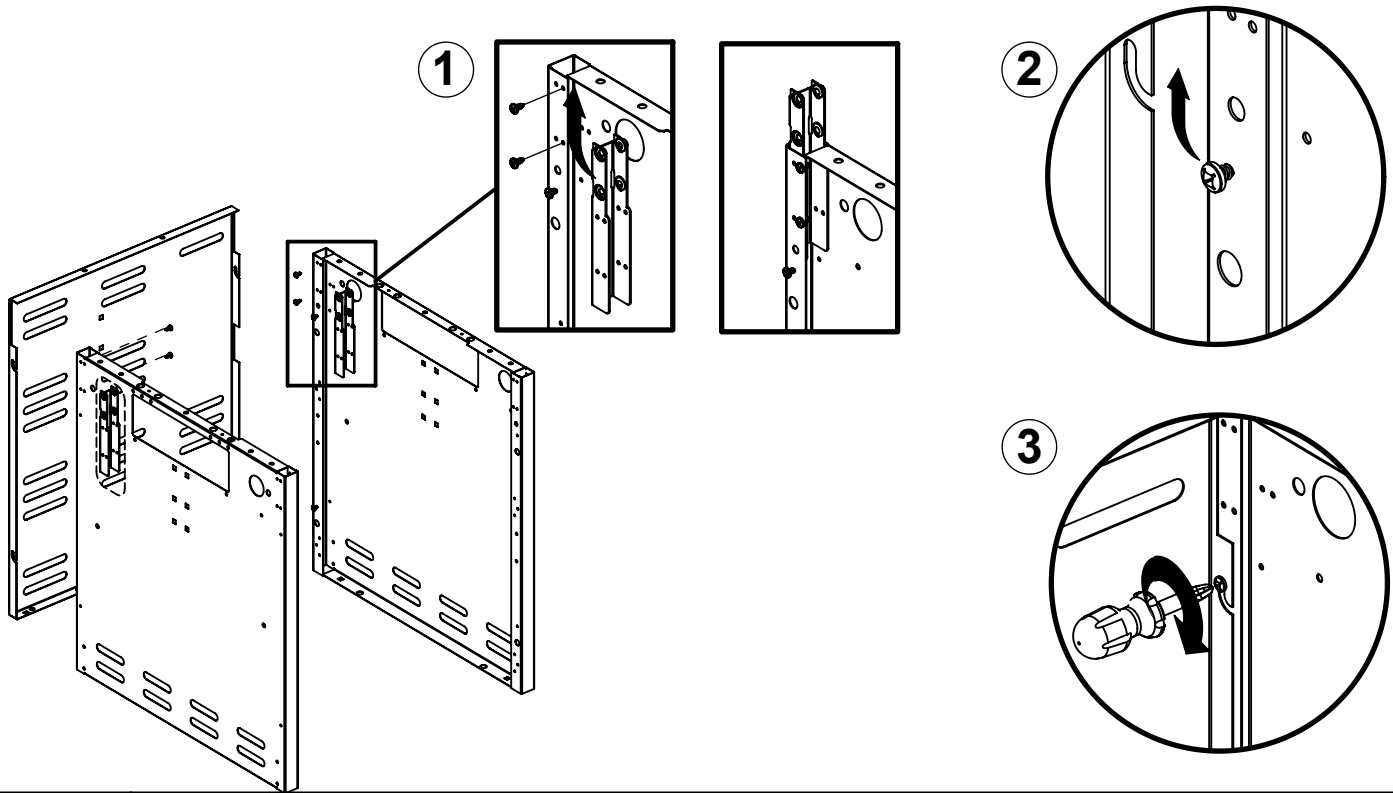

**4**

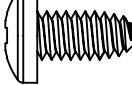
(6) 

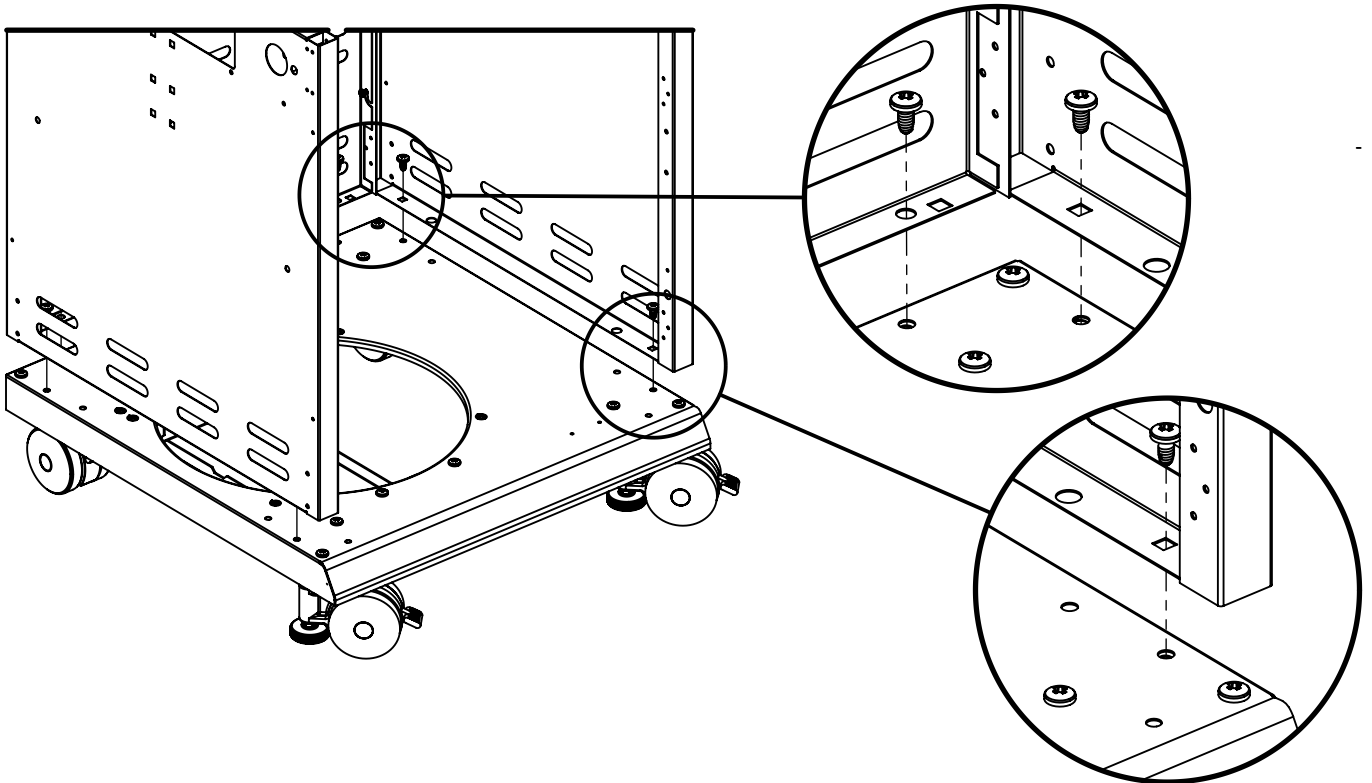

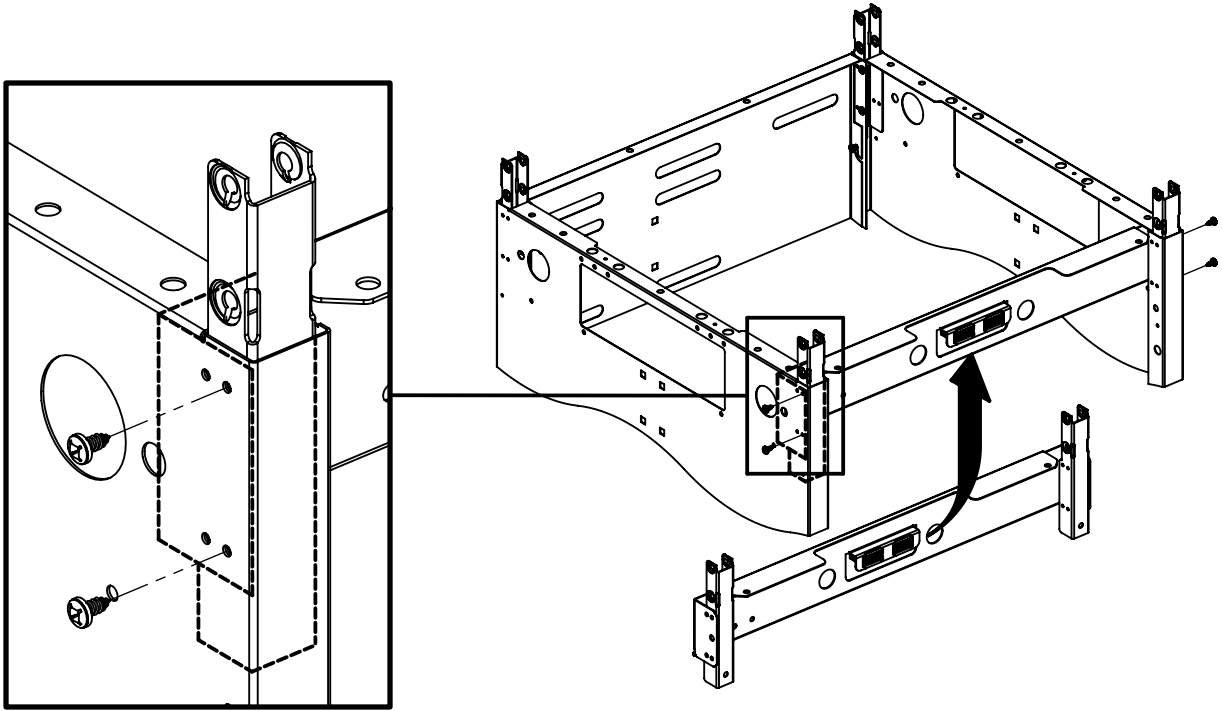

**5**

(4) 

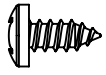

**6**

(4)  (1) 

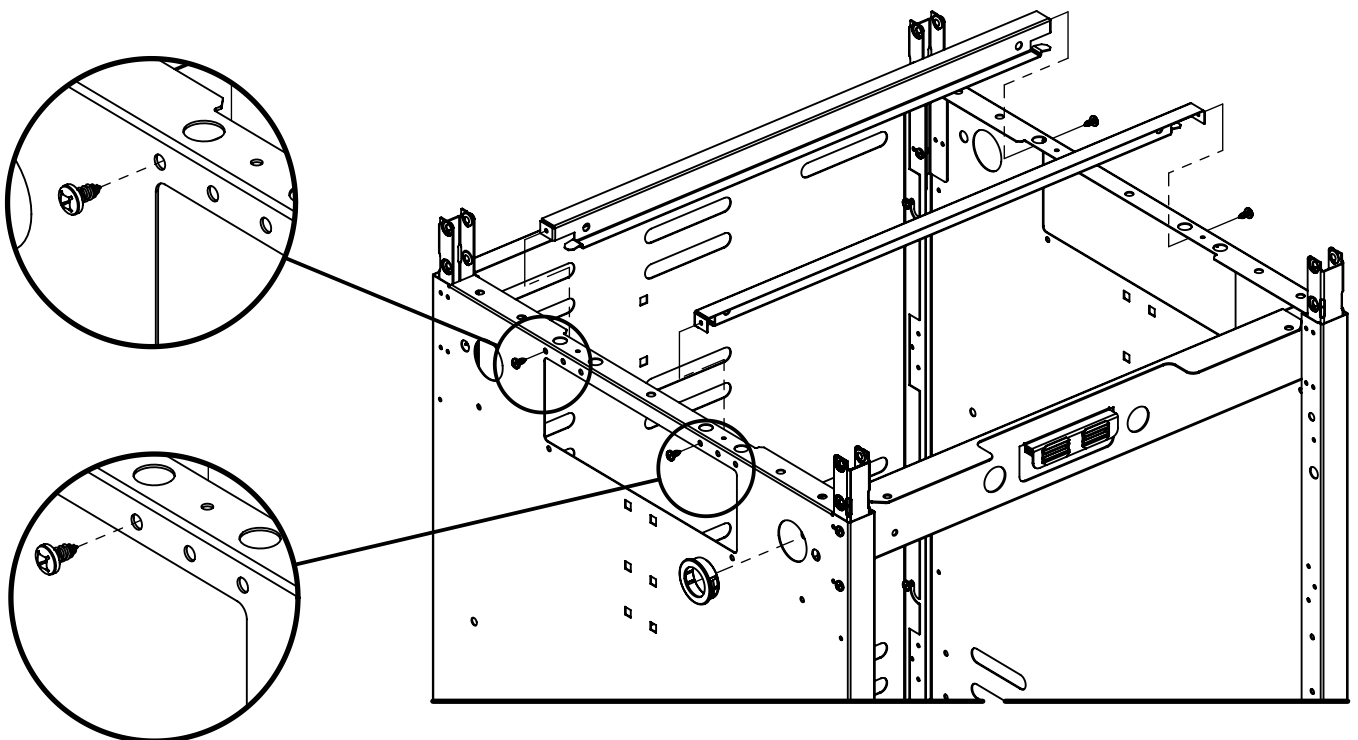

7

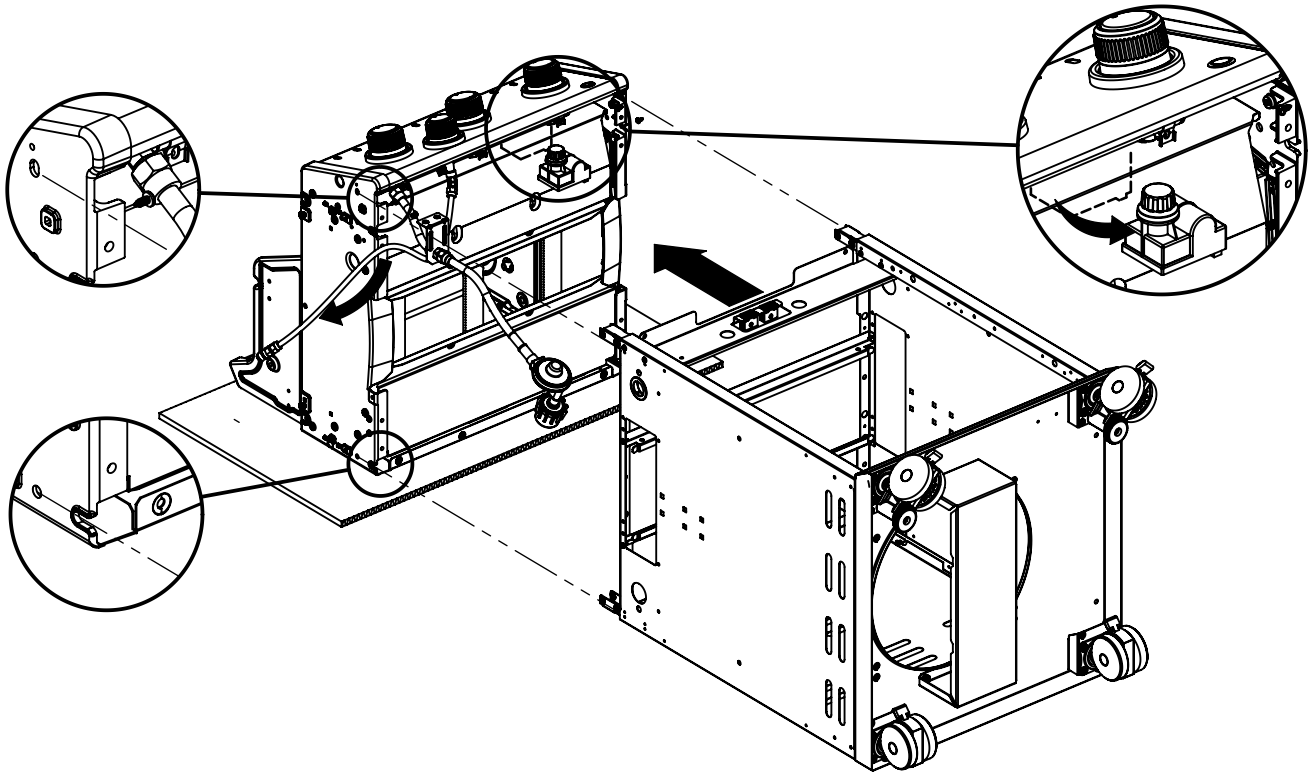

8

- (6)  A    (2)  B    (1)  C

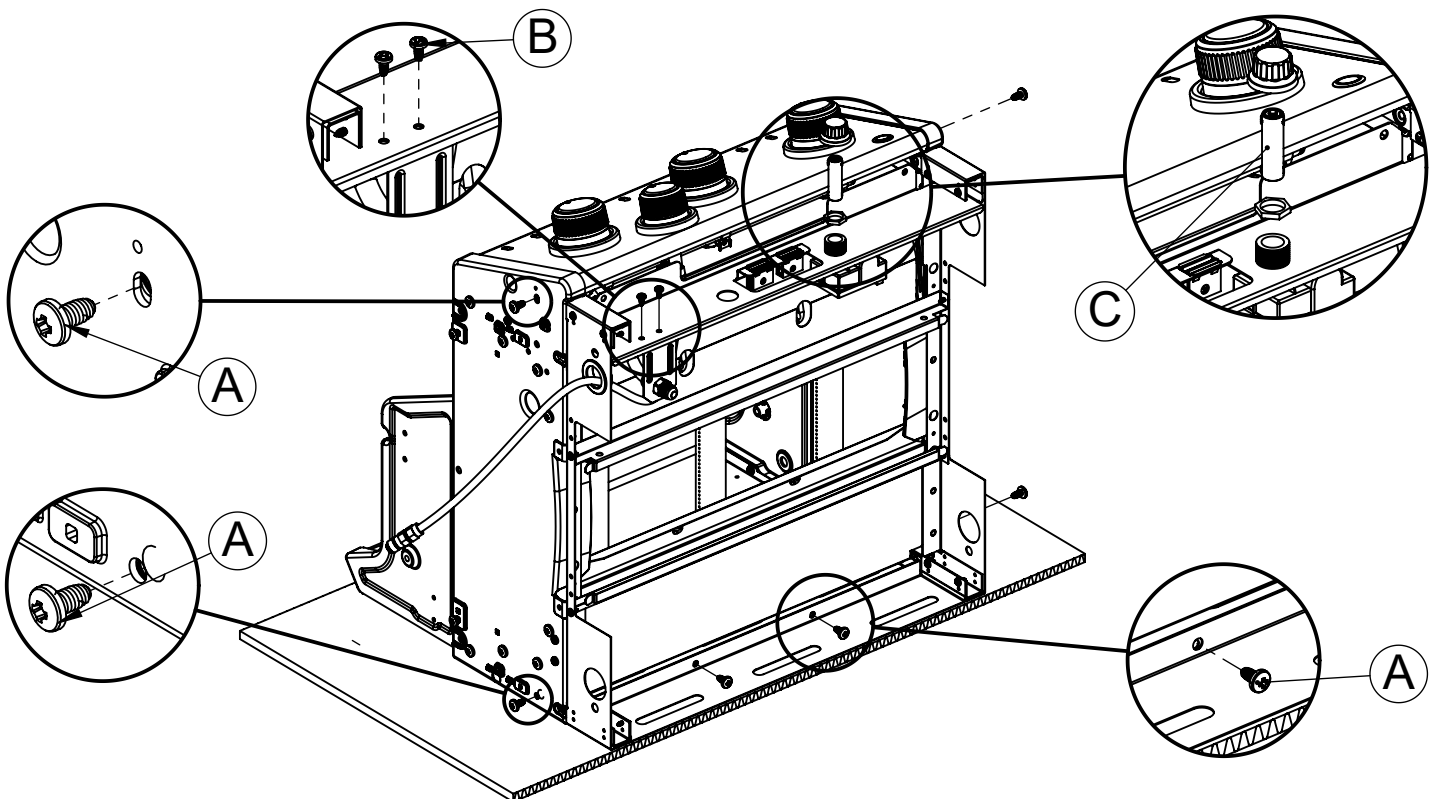

9

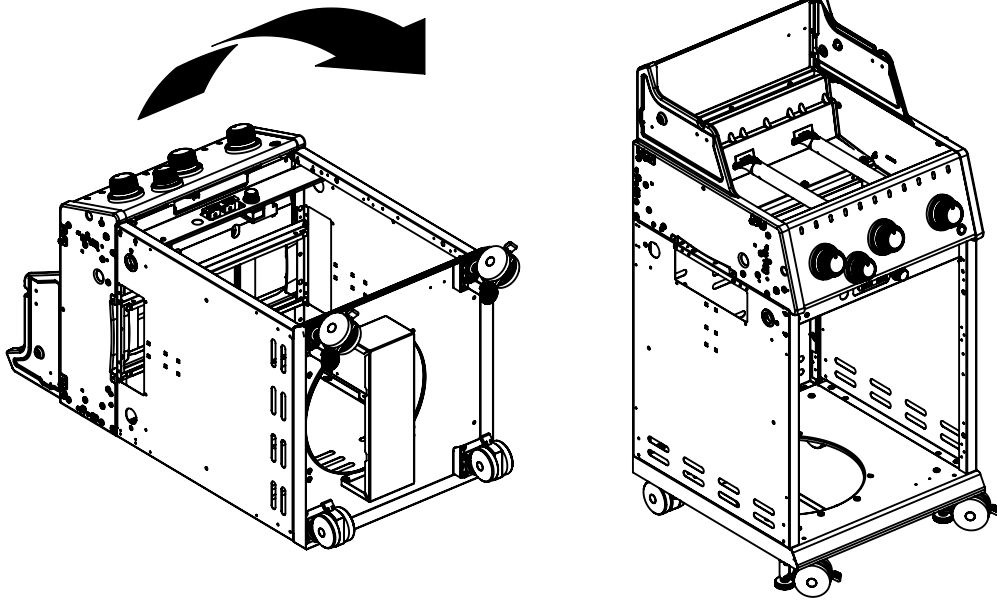
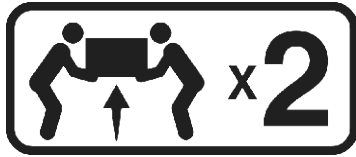

10

(2)

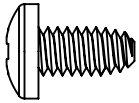

(2)

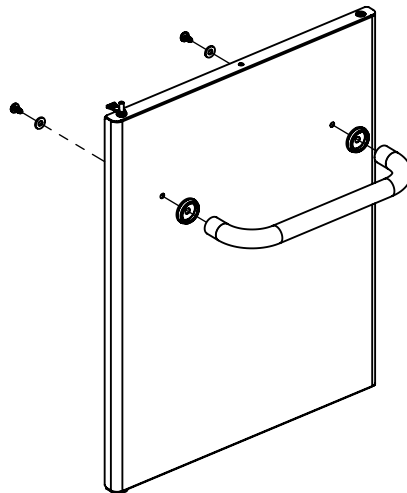
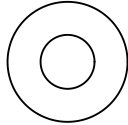

11

(1)

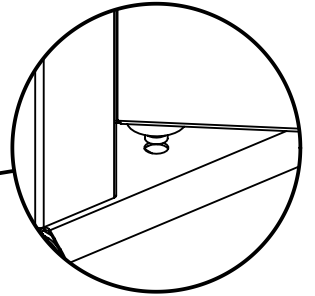
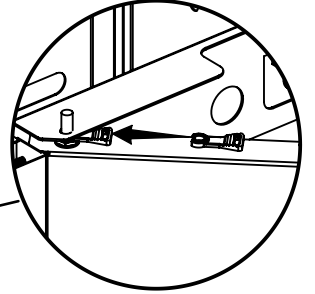
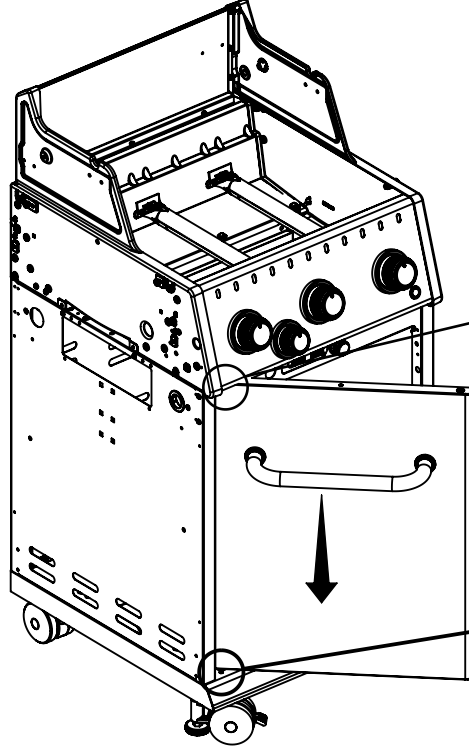
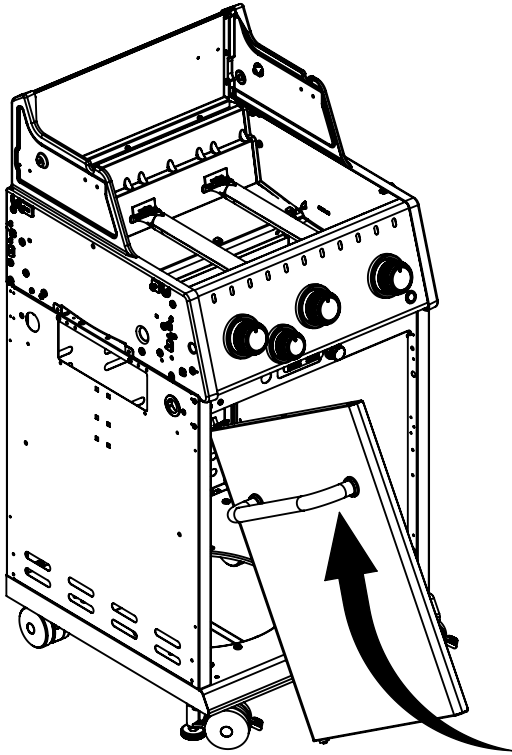
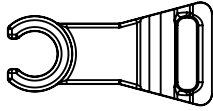

12

(1)

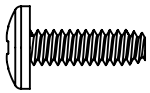

(1)

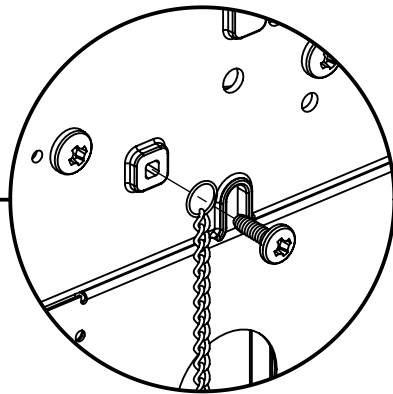
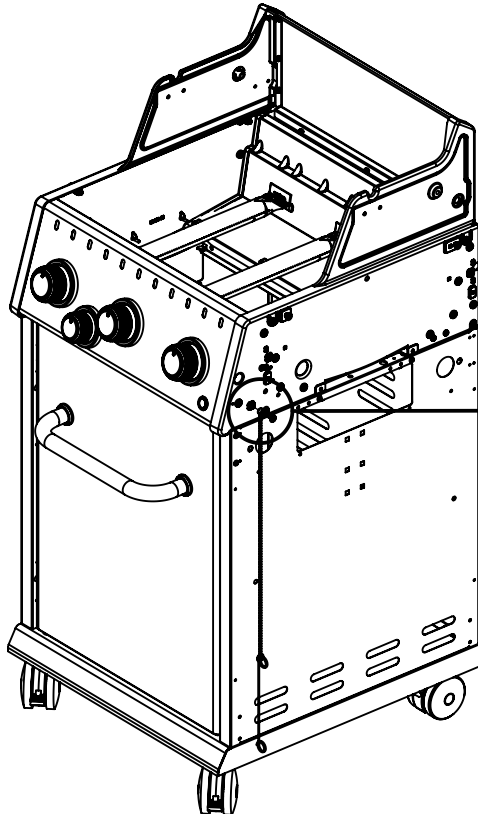



13

(4)

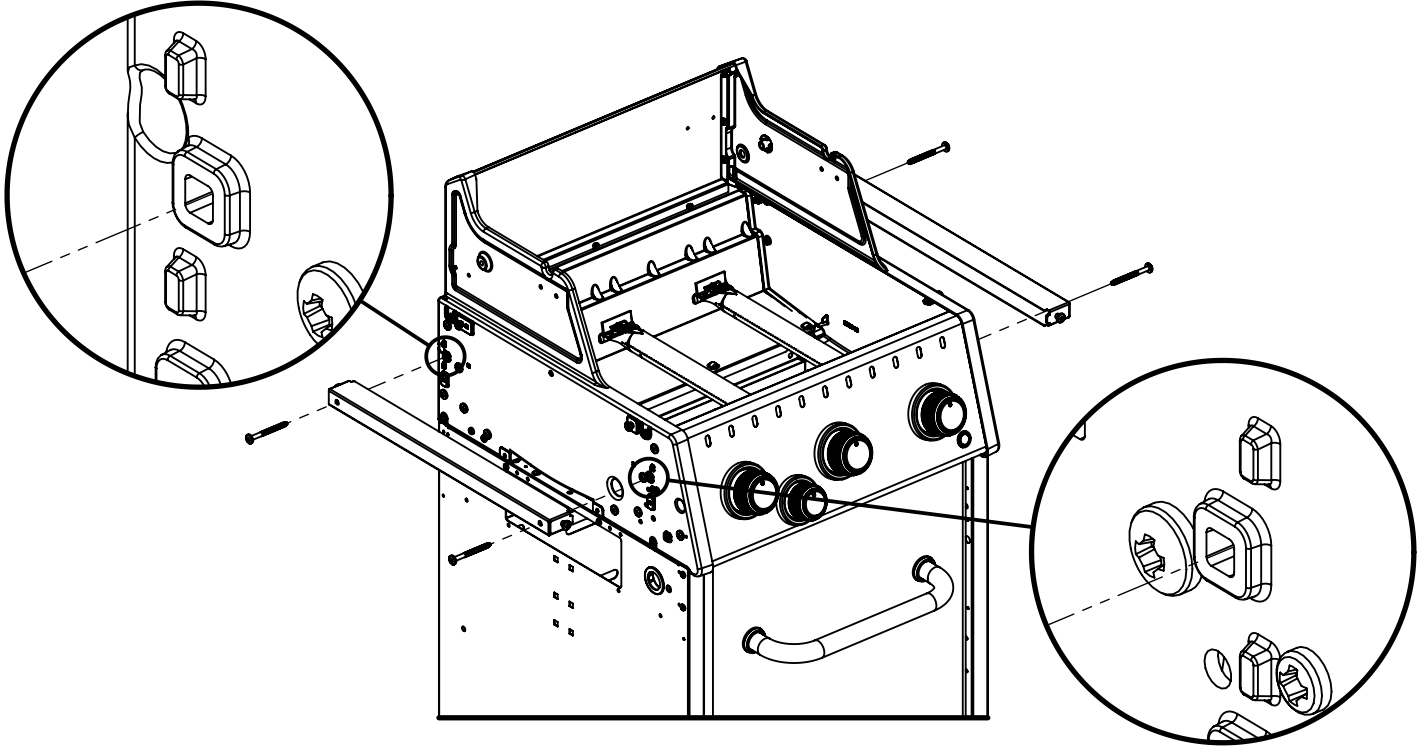
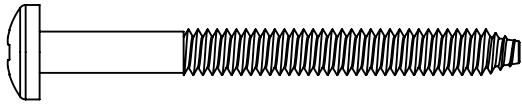

14

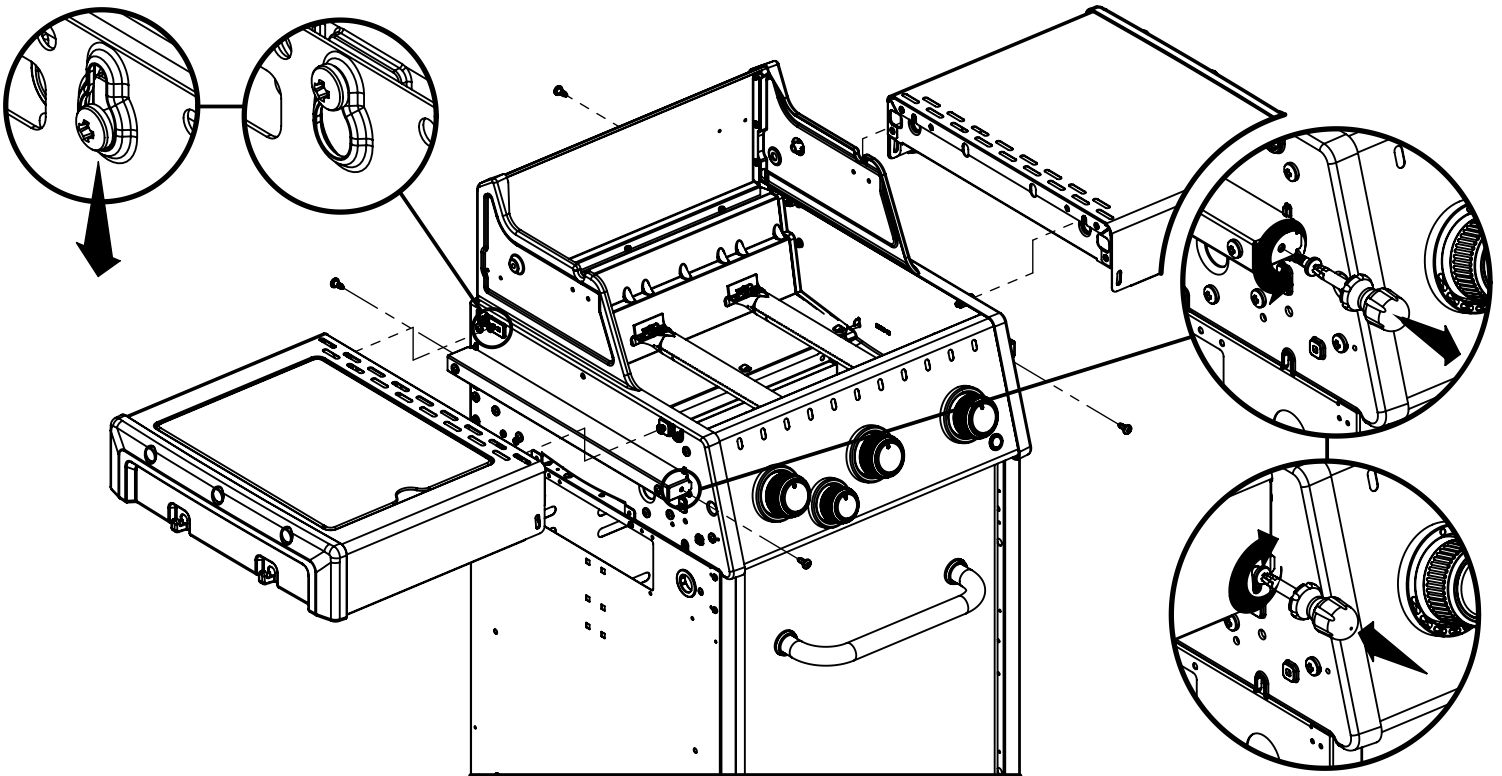

15

(4)

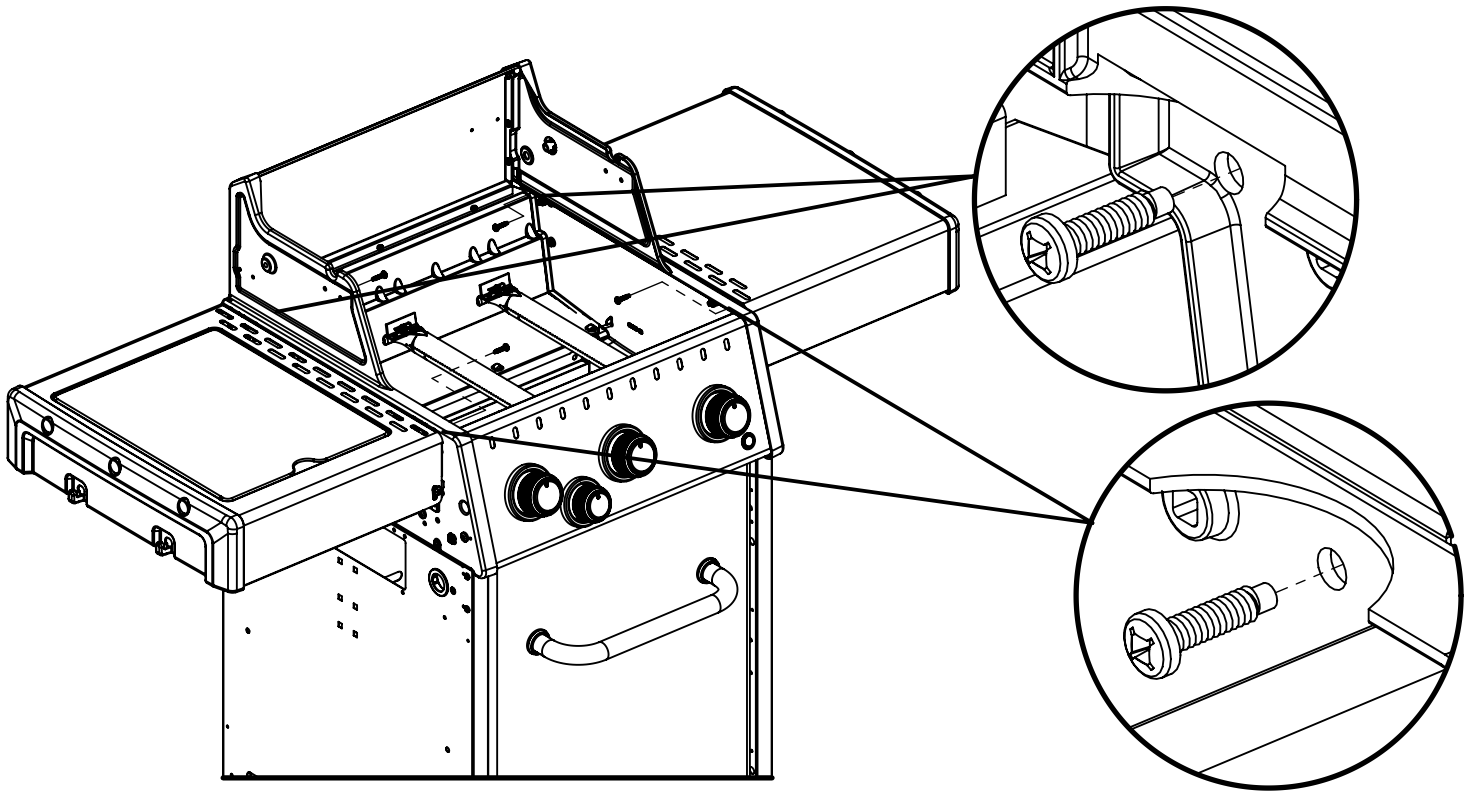
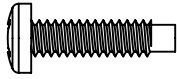

16

(1)

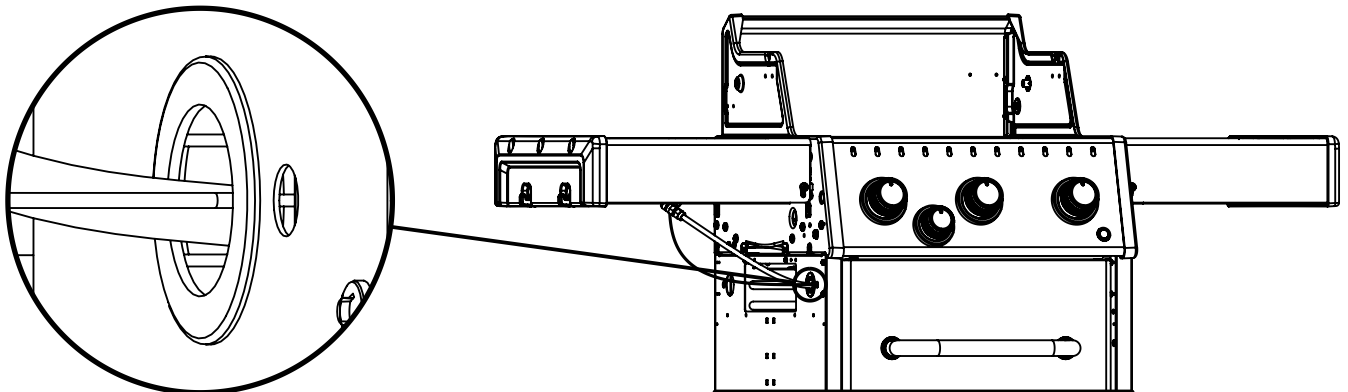
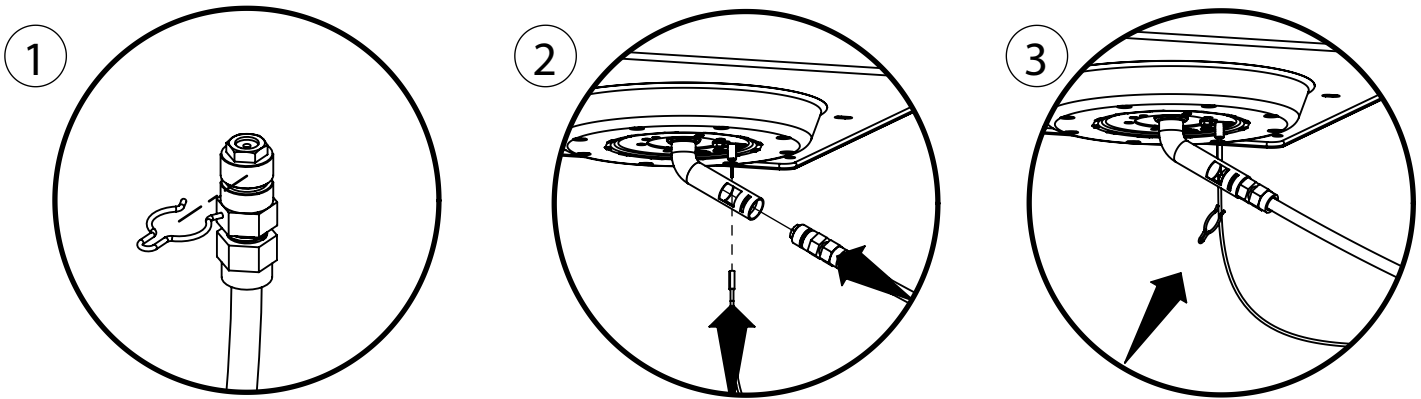
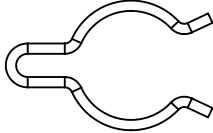

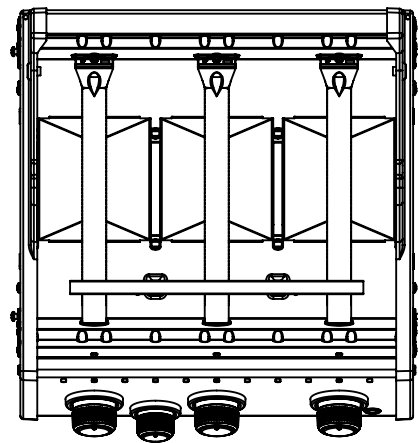
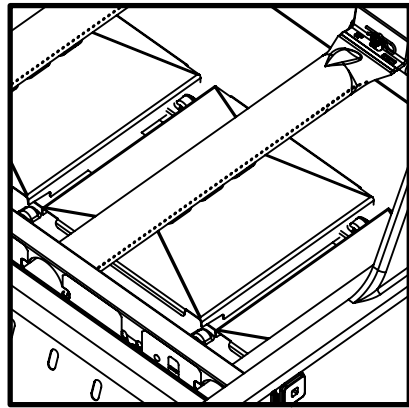
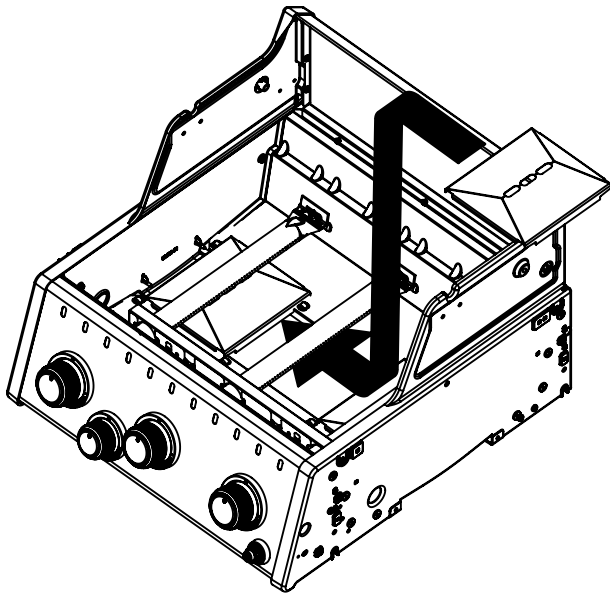
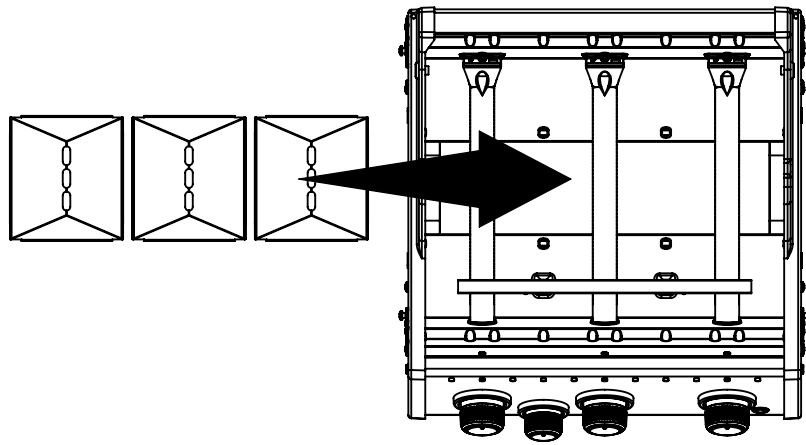

18

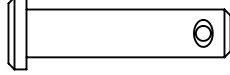
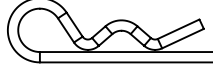
(2)  (2) 

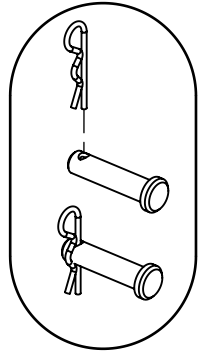
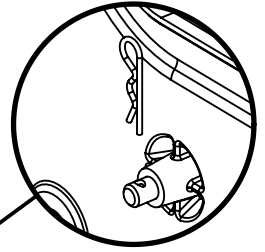
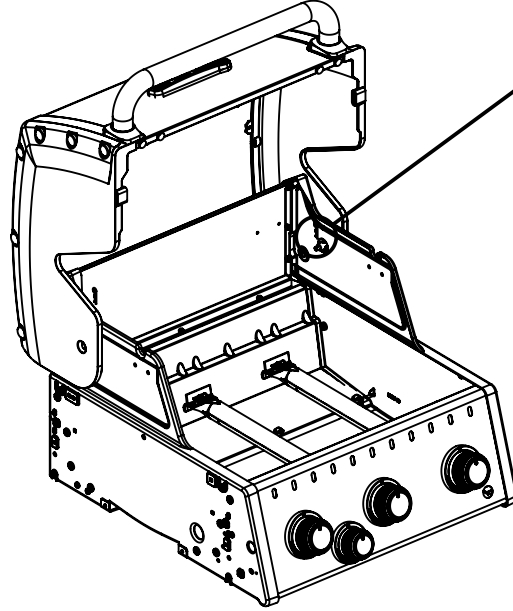
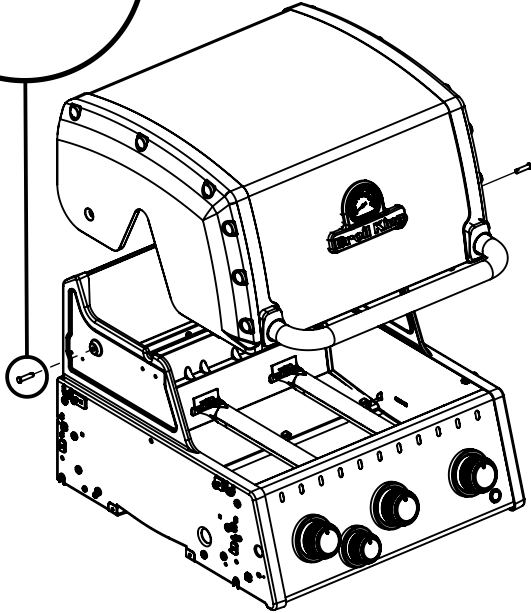
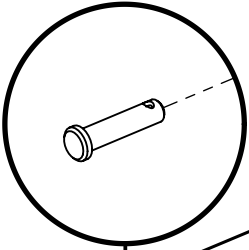

19

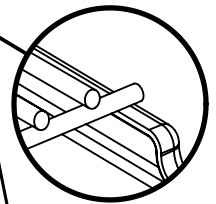
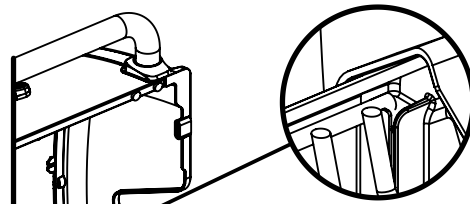
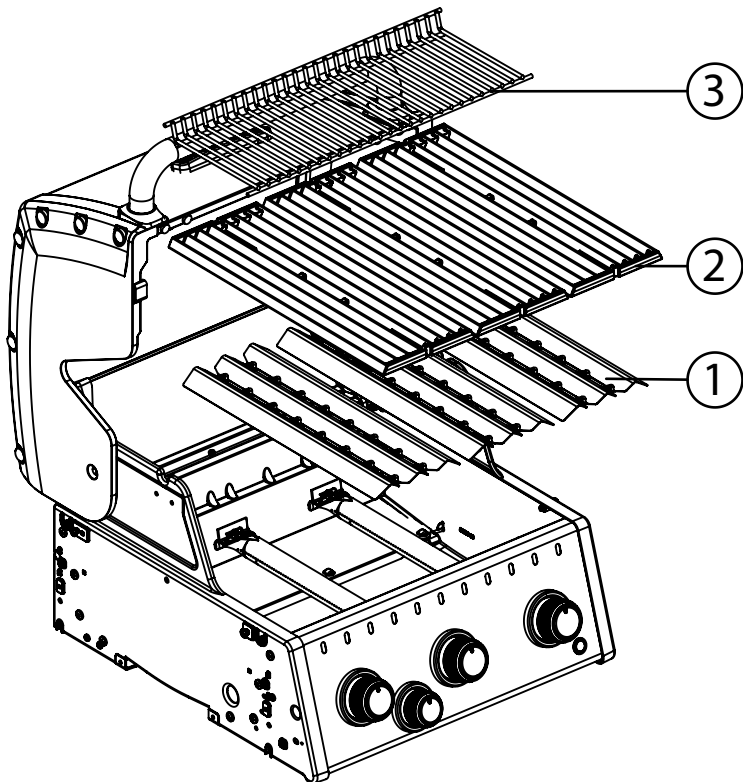

20

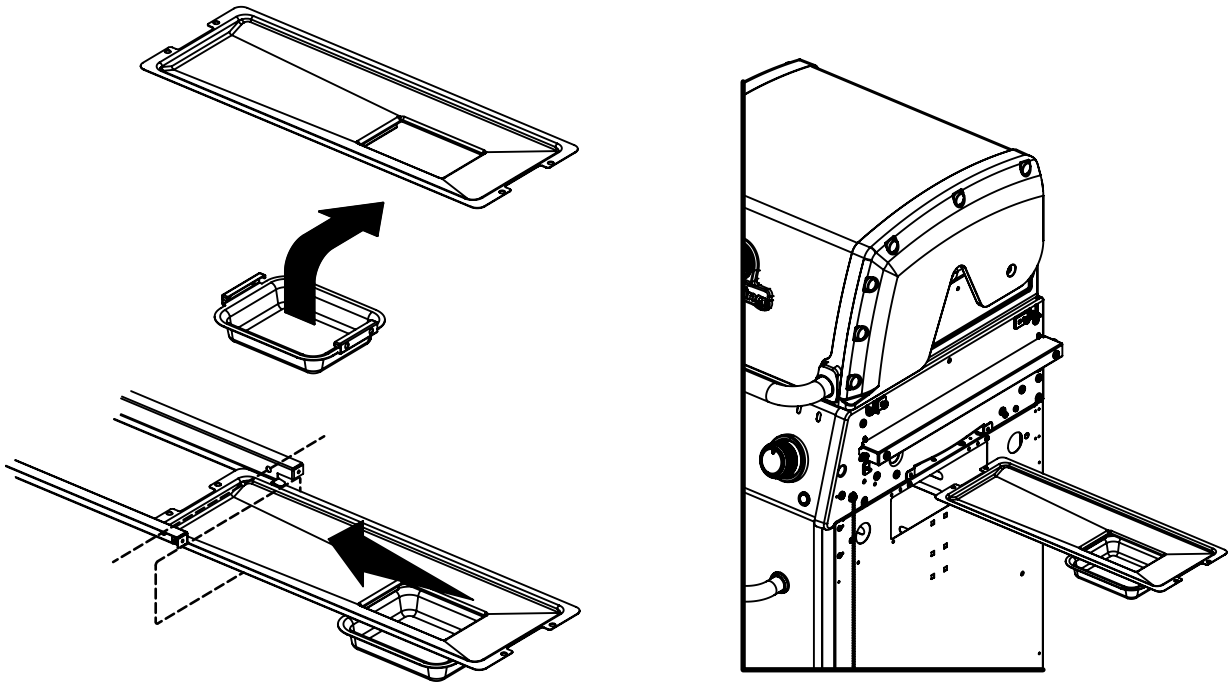

21

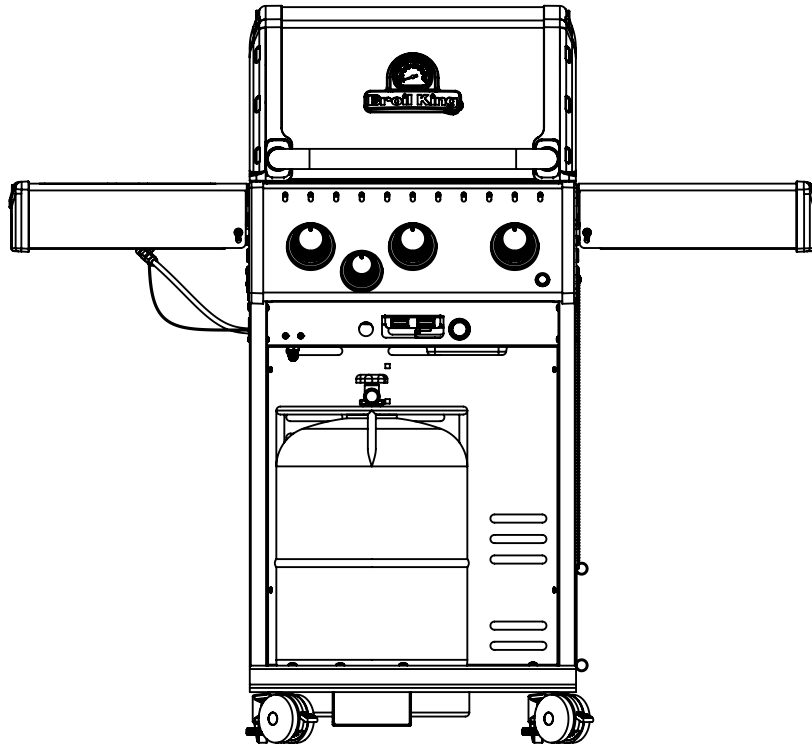

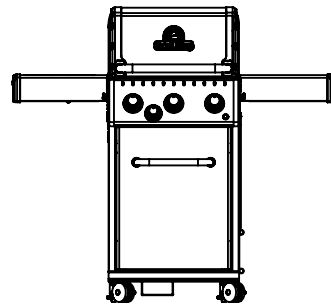
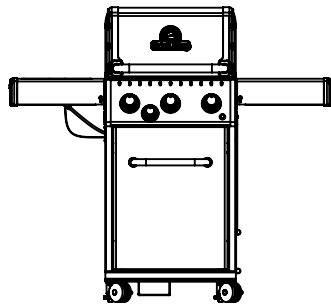

1

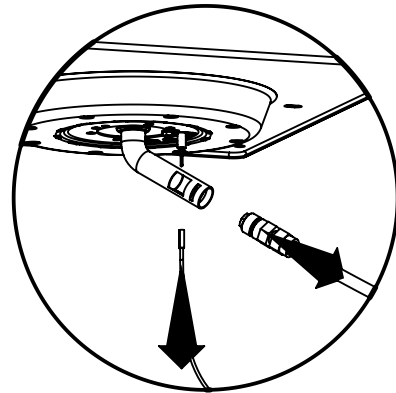
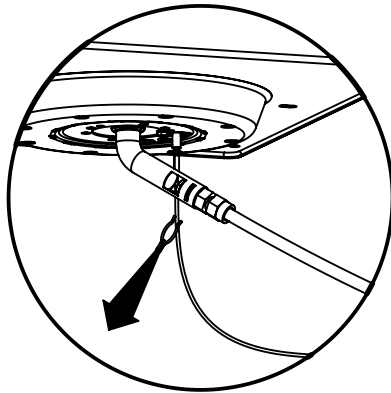

2

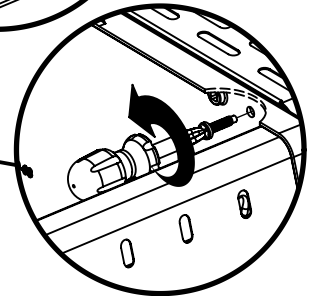
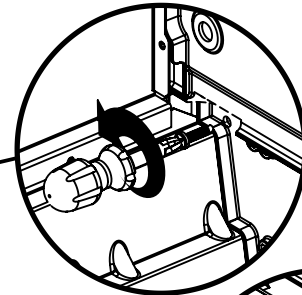
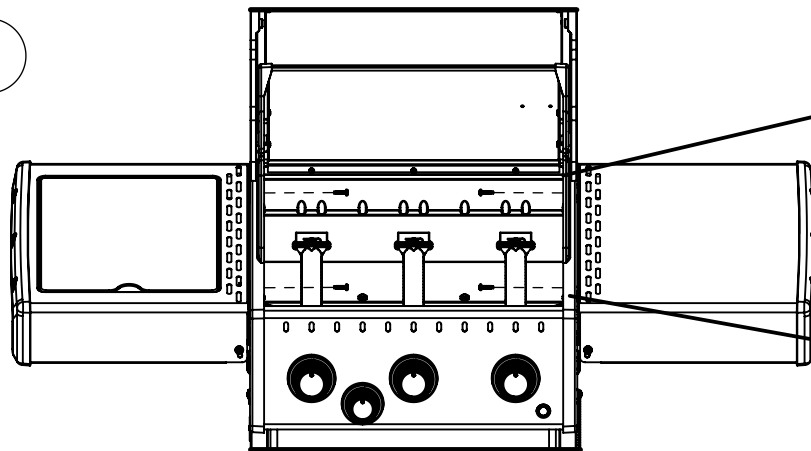

3

